

ITEA PO Days 2023

How to shape your PO

ITEA PO Days 2023, 13 September - Berlin
Erik Rodenbach -
ITEA Programme coordinator

25
years



ITEA 4
1998-2023

Project Outline Annex template

Table of Contents

Foreword (IMPORTANT, READ FIRST)

Project key data

Project acronyms

1. One-page project executive summary

2. Project overview

2.1. Rationale of the project

2.1.1. Problem statement

2.1.2. Solutions, challenges & objectives

2.2. Market view

2.2.1. Market State-of-the-Art analysis and market value chain

2.2.2. Project market impact

2.2.3. Partner market access

2.3. Technological view

2.3.1. State-of-the-Art (SotA) analysis

2.3.2. Technological innovation

2.3.3. User Value Analysis

2.3.4. Expected project outputs and KPIs

3. Partner descriptions

4. Rationale for public funding

Annex A: Summary of costs & effort breakdown

Market view

Market State-of-the-Art (SotA) Analysis

- A market SotA analysis is an analysis of the current market you are aiming at with your solution/innovation
- A market SotA analysis should cover the following topics:
 - Describe the scope of your targeted market in terms of location (national, region, worldwide,..) and targeted type of customers
 - Describe the current existing products or services in the market and what are their strong and weak points
 - Describe who are the main competitors in this market
 - Describe the influencers (regulations, integrators & distributors, ..) of this market

Market view

Market value chain analysis

- What is a market value chain?
 - Representation of the various processes producing products or services and delivering them to the market
 - A market value chain diagram shows the different actors in the chain adding value and finally delivering those product or services to the customer/end user
- What is indicated in a market value chain?
 - Where and how value is created and by whom
 - Actors' positionings and relationships and what is the money flow
 - Peripheral actors and factors (e.g. regulations, integrators, distributors, ..) who influence the market(s)

Market view

Market value chain diagram

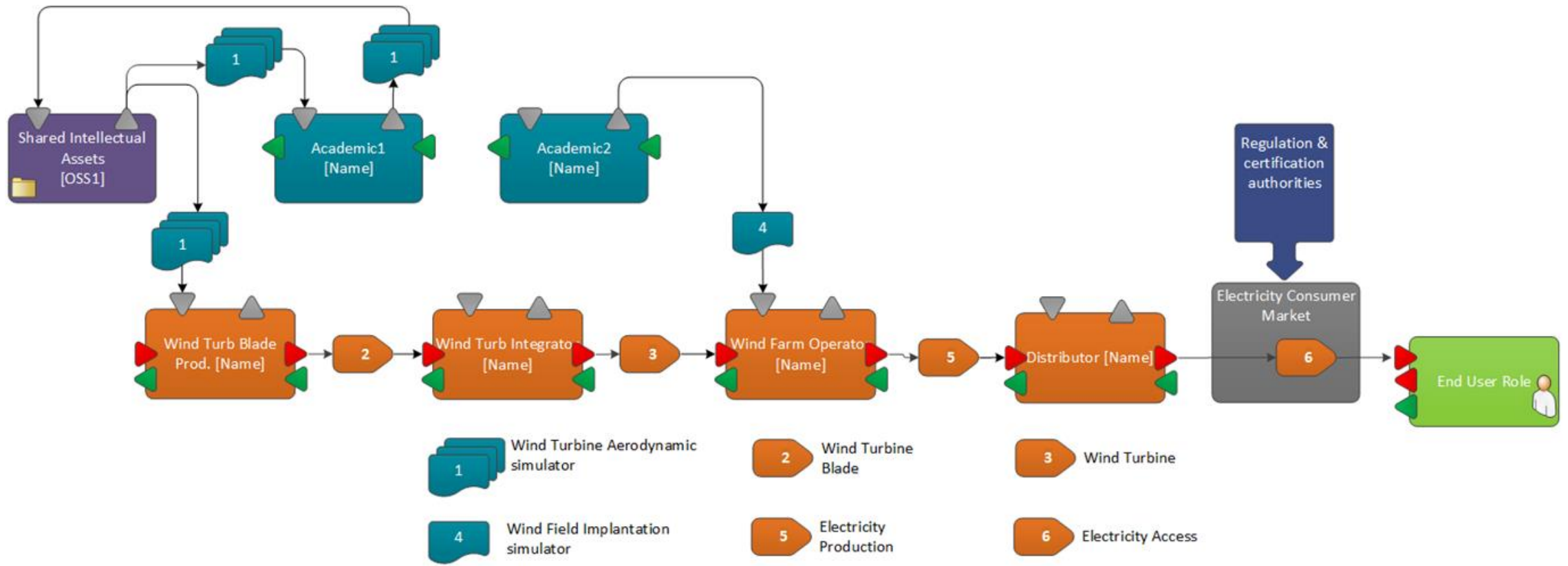

- *Note: A more detailed description of the market value chain analysis is included in the PO template package*

Market view

Project market impact

- ITEA projects are international collaborative research projects
- Collaboration is working together on a common topic
 - Clarify the added value of working together
 - Clarify the targeted joint developments
 - Clarify how the different partners will contribute to the joint developments
 - Clarify how the joint developments will benefit the partner's market impact

Technological view

User Value Analysis

- Identify what added values the innovations have for the users
- Prepare a table mapping the innovations and the identified user values

| Innovation | User value 1 | User value 2 | User Value 3 | ... | User Value n |
|--------------|--------------|--------------|--------------|-----|--------------|
| Innovation 1 | x | x | | | x |
| Innovation 2 | x | | x | | x |
| Innovation 3 | x | x | x | | |
| ... | ... | | | x | x |
| Innovation n | x | x | | x | |

Technological view

Project outputs and KPIs

- Project Outputs:
 - Define the what the project will deliver at the end
 - Quantify your targeted project output (KPIs)
- Key Performance Indicators (KPIs):
 - Represented by three values (Initial, Current, Target)
 - Project management tool: monitor the progress of the targeted achievements
 - Unique selling proposition

Technological view

Project outputs and KPIs

- KPIs must be SMART:
 - **S**pecific (the KPI must be unambiguous)
 - **M**easurable (the KPI must be measurable in order to: indicate its progress, prove if the target has been reached and serve as a commercial argument to sell the final solution after the project)
 - **A**chievable (the KPI must be achievable by the current consortium)
 - **R**elevant (the KPI must demonstrate the uniqueness of the project results)
 - **T**imely (the KPI must be achievable within the project's time frame)

Thank you
for your attention

X @ITEA_4 | #PODays2023