



BIMy Project:

D5.2 Demonstrations Available Online

Version II

Document metadata

Date	2021-03-21
Status	Final
Version	3.0
Authors	Alper Kanak – ERARGE Salih Ergün – ERARGE İbrahim Arif – ERARGE Osman Kumaş – NETAS Gözdenur Yeşilyurt – NETAS Stijn Goedertier – GIM Olivier Gillin – Aproplan Sergio Ristagno – Aproplan Steven Smolders – GIM Hashmat Wahid – Willemen Construct Dieter Froyen – Willemen Construct Lise Bibert – Willemen Construct Thomas Goossens – ASSAR Architects
Coordinator	Alper Kanak - ERARGE
Reviewed by	Gözdenur Yeşilyurt - NETAS

Version history

Version	Date	Author	Change
0.01	2019-03-22	Alper Kanak	Introduction and scope
0.02	2020-01-28	Stijn Goedertier	Add reference to business models in D4.2
0.03	2020-02-28	Stijn Goedertier, Olivier Gillin, Thomas Goossens, Dieter Froyen	Belgian demos first inputs
1.0	2020-06-01	Alper Kanak	First main draft
2.0	2020-06-20	Alper Kanak	Finalised
2.1	2020-11-07	Alper Kanak	Version II initiated
2.2	2021-03-18	Steven Smolders	Update GIS contributions
2.3	2021-03-19	Alper Kanak	Section 5 added
2.4	2021-03-19	Alper Kanak	Final draft Ready for review
2.5	2021-03-21	Gözdenur Yeşilyurt	Final draft reviewed
3.0	2021-03-21	Alper Kanak	Final for submission

Table of Contents

Table of Contents	3
1. Executive Summary	4
2. Rationale and Motivation behind the Demonstrations	5
2.1. Introduction	5
2.2. BIMy Rationale and Motivation - Revisited	5
2.3. Business models	6
2.4. Updates in D5.2 Version II	6
2.5. Influence of COVID-19	7
3. Demonstrations & Trials – Second Iteration (½ Year2 and Year3).....	8
3.1. Consolidated BIMy Platform.....	8
3.2. Automatic generation of urban context for design and construction	21
3.3. Revit model checker – Naming Conventions Checkset	25
4. Demonstrations & Trials – First Iteration (Year1 and ½ Year2)	27
4.1. Demonstration (Demo-0) / BIMy in Smart City Expo World Congress (SCEWC) 2019, Barcelona.	28
4.2. Demonstration (Demo1) / BIMy Web Viewer integrated with BIMy API.....	31
4.3. Demonstrator (Demo 2 & 3) / Digital building permit on-site inspection set-up and execution & BCF API for interoperability between BIMy and other BIM platforms	33
4.4. Demonstrator (Demo 4) / VR Disaster Training Simulator	37
4.5. Demonstrator (Demo 5) / Revit model checker	39
4.6. Demonstrator (Demo 6) / BIM-based minimal daylight criterion & acoustic insulation checks....	41
4.7. Vision (Vision 7) / Long term vision – circular economy (concept)	43
4.8. Demonstration and Vision (8) / Digital building permit app	45
4.9. Demonstrator & Vision (Demo 9) / BIMy – BIM and GIS integration in architecture	47
4.10. Demonstrator (Demo 10) / Security demo.....	49
5. Qualified Assessment of BIMy	53
5.1. Cluster I: Experts’ Profile (A.General).....	53
5.2. Cluster II: BIM Awareness (B. Personal Experience).....	53
5.3. Cluster III BIM Awareness at Organisational Level (C. BIM Organisation Experience).....	54
5.4. Cluster IV. Demand Analysis (D. Demand on BIM-GIS-IoT combined solutions)	55
5.5. Cluster V. BIMy Assessment (E. Opinions on BIMy)	56
5.6. Discussion	57
6. Conclusion.....	58
Bibliography	59

1. Executive Summary

The main purpose of this deliverable is to report the demonstration and piloting activities, either online or at field, which has been held throughout the project. This second version is built on the first version of D5.2 covering the new demonstration and piloting activities mostly in the second half of the project (Iteration#2). Apart from D5.1, D5.2 mainly focuses on the impact of the demonstrators, such as the extent and diversity of the reached community, scientific and economic benefits and future provisions.

The demonstrators are clusters in two iterations:

- Iteration 1 covers the Year1 and partly Year2 activities (Months: M1-M18).
- Iteration 2 covers the activities held throughout the rest of the project (Months: M19-M36).

The organisation of the deliverable is as follows:

Section 2 revisits the rationale and motivation behind the demonstrations and also the main updates in the second version of D5.2.

Section 3 presents an overview of the demonstrators and piloting activities held in Iteration 2 and their results over a consolidated approach.

Section 4 presents an overview of the demonstrators held in Iteration 1 (D5.2 Version I) and their impact in the first half of the project.

Section 5 the results of the qualified assessment of BIMy.

Section 6 concludes the D5.2 Version II.

2. Rationale and Motivation behind the Demonstrations

2.1. Introduction

This deliverable aims to give a short summary of the tools, services or any software that are being prepared to be demonstrated in various platforms. The demonstrations have been planned in a bottom-up integration strategy. As depicted in Figure 1, in the first year of the project country-specific use cases and related standalone demonstrations were planned and realised. D5.1 Version I gave an overview of the presented standalone tools. These tools were the first results of re-elicitation of the available capacity in the consortium and the reflection of possible re-usable technologies or first developments.

The second year considers an integration over the BIMy platform. Here, the presentable tools and demonstrations were integrated up to some extent. The third year finally presents the combined demonstration and assessment of results, best practices and lessons learnt, especially the ones over the BIM Platform.

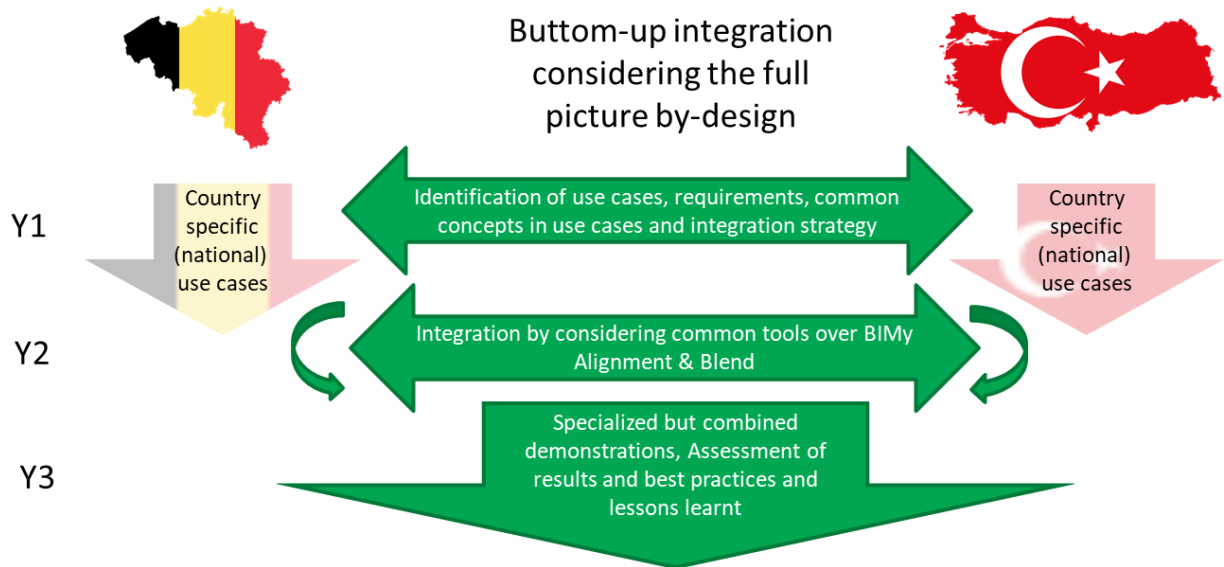

Figure 1. BIMy integrations and demonstration strategy

Hence, this deliverable gives an inventory of:

- the demonstrations presented online,
- the outcomes of the workshops or stakeholder interviews where project outputs are presented and expert opinions are gathered,
- the reflections of public events (exhibitions, conferences, fairs, etc.),

in a nutshell.

2.2. BIMy Rationale and Motivation - Revisited

The BIMy project aims at providing an open collaborative platform for sharing, storing and filtering Building Information Models (BIM) among different BIM owners/users and integrating and visualizing them in their

built and natural environment. BIMy can be seen as an open and generic intermediary that enables interactions between existing and new applications through a unique standardised open API platform. Such a platform provides a secure collaborative working environment where different stakeholders can benefit and/or utilize BIM models not only at a single building level but also at larger levels that can be scaled up to wider-area smart city applications.

BIMy Platform is designed to overcome the limitations of current BIM exchange platforms, providing the following features: i) BIM with scale and time (supporting different levels of details and different stages of the building lifecycle), ii) BIM/GIS semantic and dynamic integration (integrating BIM in their built and natural environment), iii) BIM filtering (providing relevant information according to stakeholders and applications), cooperation (supporting stakeholder interactions), iv) Simulation and 3D visualisation (mixed and augmented reality through different devices).

BIMy is bringing into the consortium all the actors necessary to the successful completion of the platform. There are large companies that can provide a Cloud infrastructure for hosting the BIMy platform and contribute with more resources when needed. The smaller companies offer more focused know-how to specified tasks as collaboration or BIM sharing and visualisation. The research partners support companies with more complicated problems such as creating simple API and modelling and integrating BIM and GIS at different scales and times. BIM owners/users have an important role in the definition of the requirements, modelling, in offering their expertise for different applications and business models as well as the evaluation of demonstrators. The demonstrators in both countries improve the chances to make BIMy more replicable to new countries and environments. This enhances remarkably the market potential of BIMy.

2.3. Business models

In deliverable 'D4.2 v1 Report for business and exploitation models' (BIMy consortium, 2020, p. 2) we have analysed in detail several business models for the BIMy platform, such as:

- **Online tendering: BIM4Facility Management;**
- **BIM/GIS data broker: integrate urban context information into BIM models;**
- **BIM/GIS data broker: BIM4Insurance data extractor;**
- **BIM/GIS data broker: BIM4utility data extractor.**

The business models have been analysed on the basis of literature review and validated via interviews and surveys with key stakeholders. In this deliverable, we summarise the demonstrations that we have made available online or opened to discussion over Internet. These demonstrations intend to further check the validity of the business models.

2.4. Updates in D5.2 Version II

The D5.2 Version II mainly focuses on the general and qualified assessment of the BIMy outputs. In order to measure the impact of the BIMy platform a recent questionnaire is applied to experts from different sectors, e.g. AEC, ICT, disaster management and government. In the new version of the deliverable, the consolidated BIMy platform is also presented to the experts and videos of previous BIMy achievements have been shown for qualified assessments. Thus, Section 3 and Section 5 are the new advancements presenting the consolidated demonstrations and the interview results, respectively.

2.5. Influence of COVID-19

Travelling restrictions continued to have an unpredictably limiting effect on the ability of the Partners to hold physical meetings and showcasing BIMy demonstrations to the related stakeholders and potential users of BIMy. The consortium was deprived of any sort ranging from steering committee meetings, workshops, develop-debug boot camps and attending conferences due to the lockdowns. For contingency planning the Consortium followed a COVID-adapted dissemination and demonstration implementation strategy through Iteration #2 by relying on online virtual meetings, and effective use of online data repository and folders for document, data and tool sharing as usual.

COVID-19 has mainly influenced the activities in the second iteration. The recovery and mitigation strategy is applied by first focusing on the real experts rather than regular users (like citizens or residents). The experts are selected from a limited set but having experience from past projects where they had covered the opinions and the needs of the public. Second, online chat platforms are effectively used to reach experts. Since joint workshops are rather hard to organise, bilateral or small group virtual meeting are held. During meetings, not only the general opinions about BIM but also feedback about BIMy achievements and demonstrators are collected. The videos and teaser snippets help a lot to present the BIMy notion.

Finally, the online demonstrations and interviews with experts present a qualified assessment of the BIMy outputs. Such an assessment helps seeing the lessons learnt, gaps to be filled, good practices and future provisions.

3. Demonstrations & Trials – Second Iteration (½ Year2 and Year3)

Aligned with the use cases the following online demonstrations, trials or exhibitions have been developed aiming to present a baseline for further extensions to a wider community. This section gives an overview of these demonstrators all of which have been planned and demonstrated mainly during the second (half) year and the third year of the project (shortly second half of the project).

3.1. Consolidated BIMy Platform

The BIMy platform is a multi-layered structure created for the realisation of scenarios designed within the scope of the project. In the realisation of these scenarios, each partner takes a different task and carries out the tasks of the work packages determined on their side according to the scenarios. Collaboration and teamwork between partners have been the main motivation in the realisation of work packages. Until this period, most of the project was resolved and exploitation plans for the future project began to be made. For this purpose, how to benefit from the project in the future, how to act in order to orchestrate the platform in the future and how to plan in case of a possible sale are within the scope of D5.2 as addressed in Section 5. Note that BIMy Platform is hosted by NETAS.

As illustrated in Figure 2, BIMy layers are i) APIs and security, ii) BIM data management, iii) GIS data management, iv) Data transformation and v) cloud infrastructure sections, which are developed applications and basic parts of the platform. Each layer, as briefly described below, is developed and deployed in the cloud environment with the valuable contributions of the consortium members:

- i. APIs and Security: Applications using BIM and GIS data developed on the BIMy platform and constitute the basic units of the platform.
- ii. BIM Data Management: The basic unit where BIM data is stored and used by applications and users to access BIM models
- iii. GIS Data Management: The basic unit where GIS data is stored and used by applications and users to access GIS data.
- iv. Data Transformation: The basic unit in which conversion of BIM and GIS data is made within the framework of specified standards
- v. Cloud Infrastructure: Microsoft Azure infrastructure. The processes such as storage, deployment and monitoring provided with the cloud infrastructure ensure the effective use of the platform by the end user.

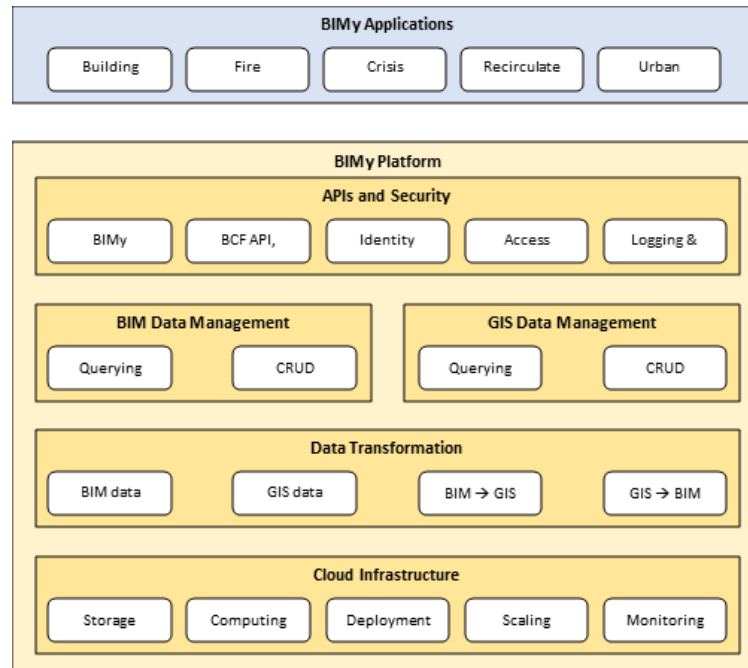

Figure 2. BIMy Platform Architecture

The final consolidated application is implemented by using the Azure Cloud facilities and context-specific developments that can be elastically scaled up according to the needs and the BIMy exploitation trend and usage statistics. The intended users of BIMy are clients, architects, designers, external advisors, contractors, facility manager, governments (urban planning, fire department, crisis management authorities, tax authorities), municipalities, insurance companies, utility companies, marketers, environmental protection administrators.

The main inputs of the platform are roughly: i) BIM & GIS model files, ii) Metadata related to BIM models, and iii) BIM-GIS-based BIMy toolsets portfolio each of which are accessible from the main dashboard as shown in Figure 3. The main outputs of the platform are the i) BIMy data manager over cloud, ii) Web-based platform with effective and user-friendly interface to BIMy toolsets, and iii) Fail or success message indicating the result of the operation.

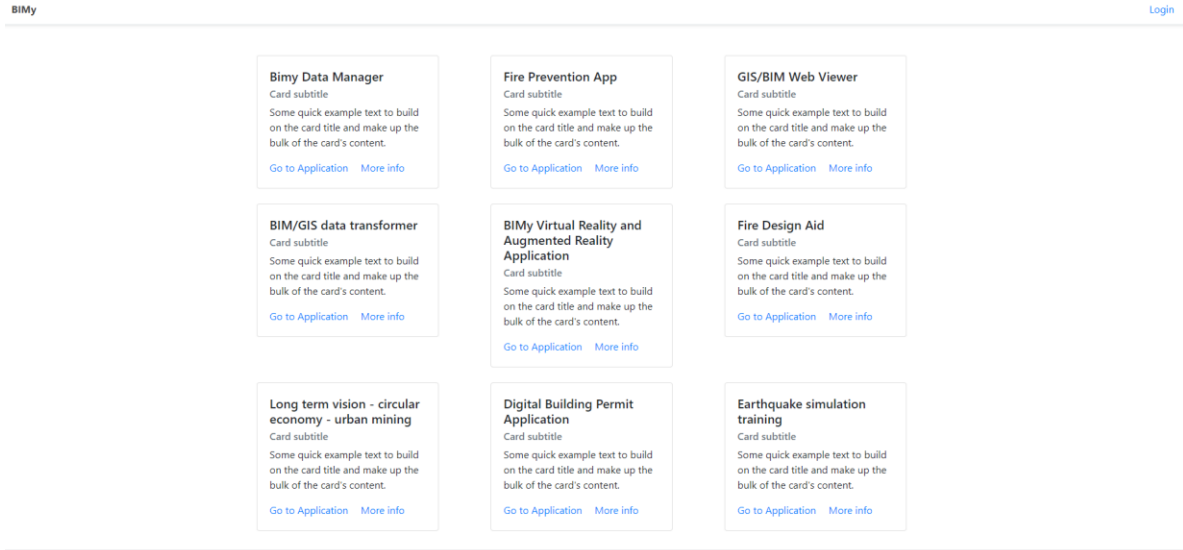
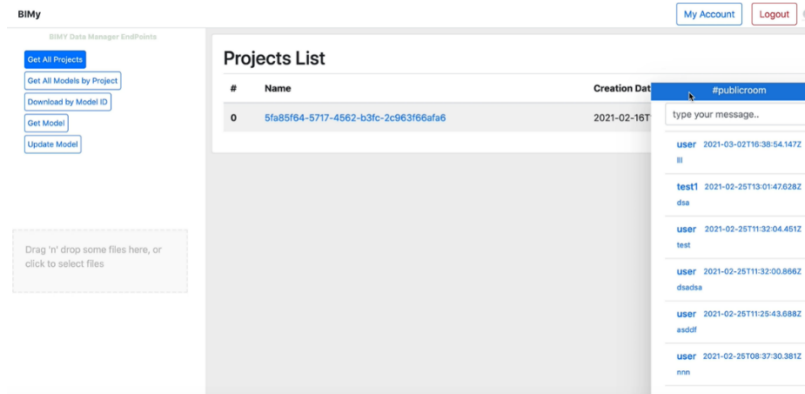
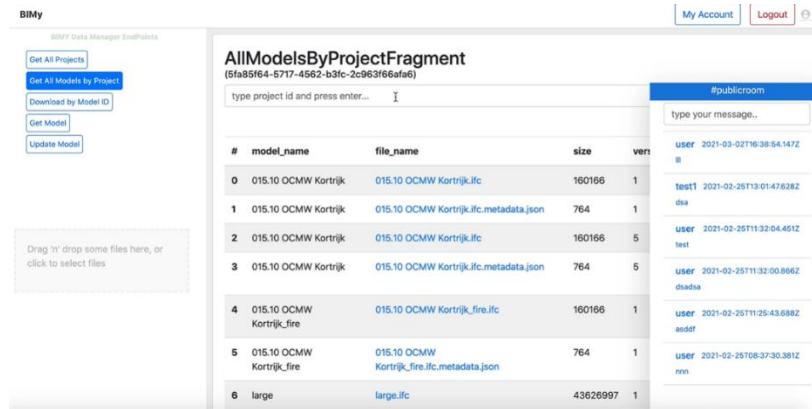

Figure 3. BIMy solutions portfolio - dashboard

The developed platform enables the management of heterogeneous BIM and GIS tools within BIMy context that is elastic to be extended and improved with new innovative tools. With the power of event-driven and non-blocking VERT.X, and the ability to handle concurrencies, any new application can be scaled up with minimal hardware. The MinIO server makes it possible to store any data within BIMy projects in a high performance, Amazon S3 API compatible object storage. As presented in Figure 4 (a) - (c) the BIMy data manager can be used to manage projects and underlying IFC files effectively.



(a)



(b)

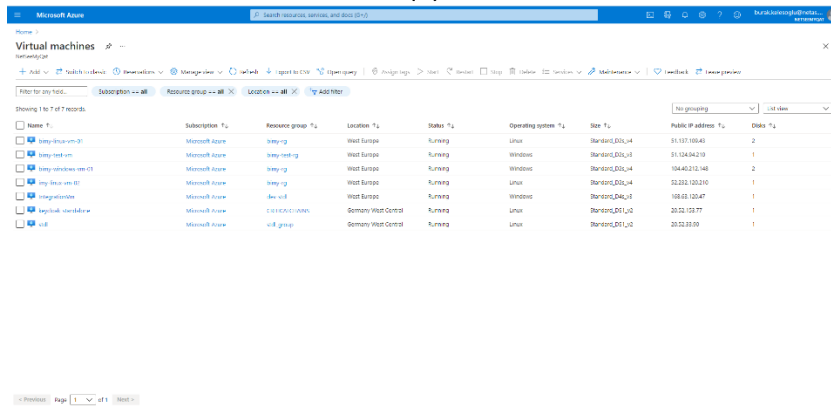

(c)

Figure 4 BIMy Data Manager (a) BIM/GIS projects (any AEC project) list and chatroom for multistakeholder collaboration; (b) IFC subprojects in a typical AEC project; (c) Virtual machines over Azure Cloud

The consolidated BIMy platform enables access to nine trending applications, yet, through its portfolio:

- Bimy Data Manager (online web application, See Figure 4)
- BIMy Cyber Security Analysis (online web application)
- GIS/BIM Web Viewer (online web application)
- BIMy Augmented Reality Application (online teaser video and downloadable mobile application in .apk format)
- BIM/GIS data transformer (online web application)
- Fire Design Aid (link to online Unity application)
- Long term vision - circular economy - urban mining (online web application)
- Digital Building Permit Application (link to outer service)
- Disaster Simulation VR Training (link to online Unity application)
- Fire Prevention App (link to online Unity application)

The following subsections present the context-specific online demonstrators which are available by the end of the project (March 2021).

3.1.1. BIMy Cyber Security Analysis

Various assignments and transactions have been made to ensure the security of the BIMy platform. These are the analysis of anomalies for cyber security and the detection and visualisation of these attacks by arranging the attacks, ensuring the secure access of the users with an OTP-based code (generated by a Hardware Security Module (HSM)) during the authentication and authorisation stage with KeyCloak during the access to BIM data and the determined cyber security needs of the platform. All such cyber resilience countermeasures are tackled by the customisation of the Azure cyber security services and the BIMY-specific developments.

The presented online tool is used for anomaly detection in a network where BIMy users collaborate with each other. Anomalies are patterns in data that do not conform to well-defined normal behaviours. In other words, anomaly detection, in a simplest sense, is a technique that enables unexpected situations or patterns in any data within the BIMY context. These unexpected situations or patterns are actually the situations or patterns that do not conform to the expected behaviour of a data. These unexpected situations are called outliers, exceptions or anomalies in the literature. A snapshot from the online cyber resilience monitoring dashboard is presented below in Figure 5.

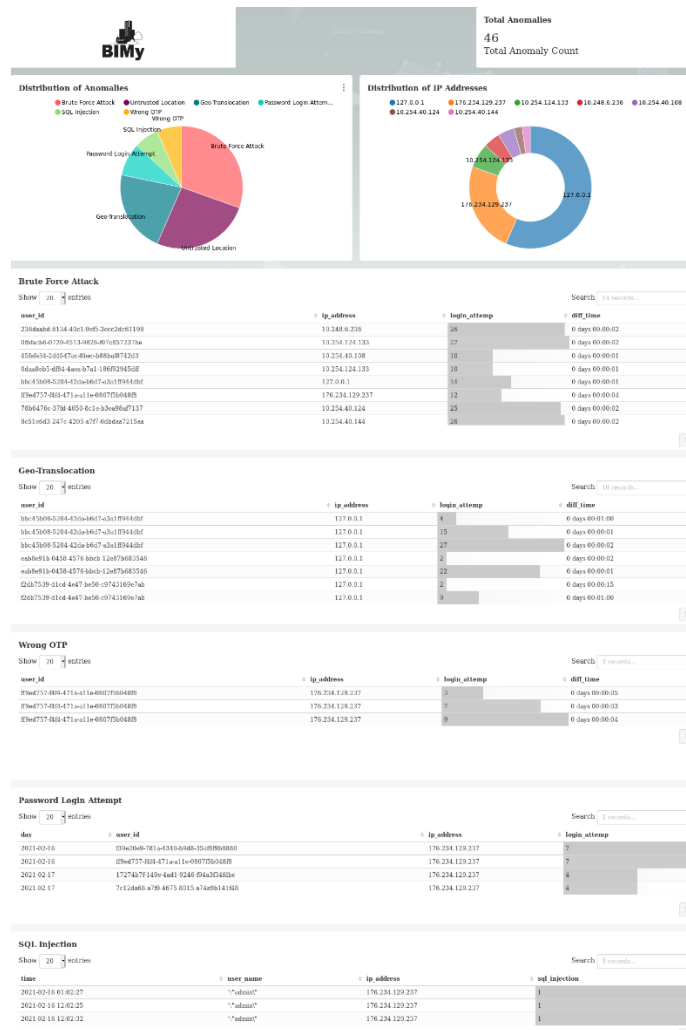

Figure 5. BIMy Cyber Resilience Monitoring Dashboard

3.1.2. GIS/BIM Web Viewer

The GIS /BIM web viewer is implemented over Web and integrated in BIMy platform. The web viewer is based on Cesium which is an open-source JavaScript library for world-class 3D globes and maps. The main motivation behind Cesium is to create the leading web-based globe and map for visualizing dynamic data. For this demonstrator, we use Cesium-based 3DCityDB's web client demo application that enables the visualisation of GIS data on a globe. The CityGML model of New York City dataset is loaded and the visualised buildings are mapped to models in our BIMServer. With this, the 1-to-1 mapping between the building's GIS model and BIM model is implemented. The Cesium-based visualisation enables effective filtering of BIM models and the visualisation of query results on a Web platform. Such query results can also be transformed in Collada or FBX format which is used for Virtual or Augmented Reality applications. Figure 6 presents some snapshots from the BIM/Gis Web Viewer.

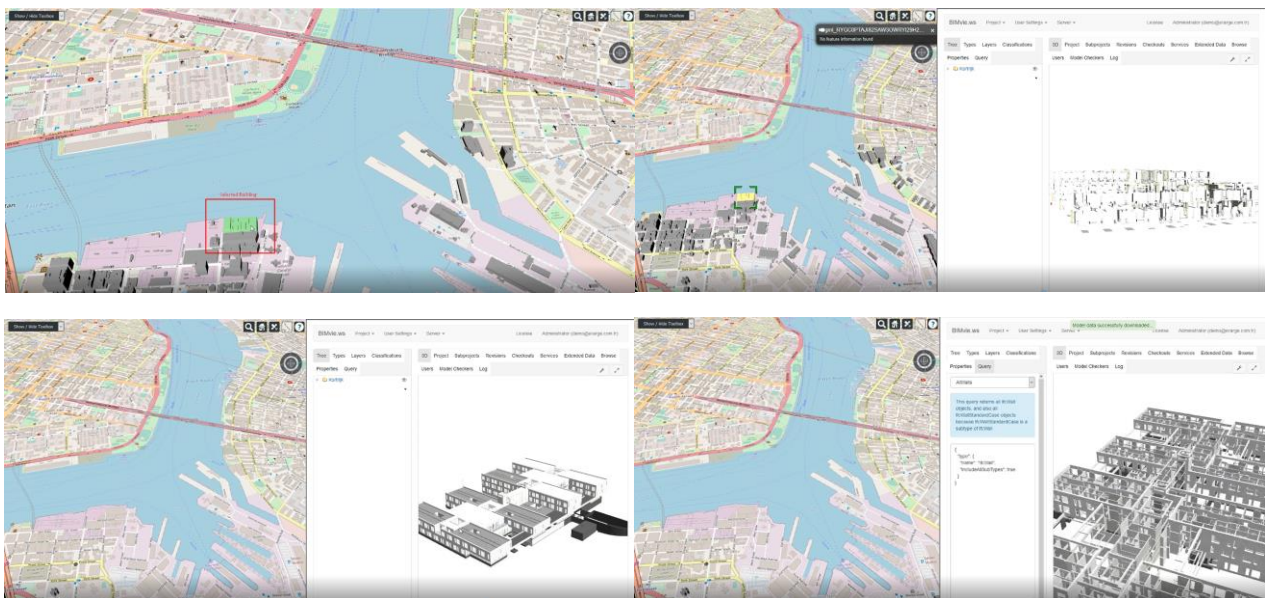

Figure 6. BIM-GIS Web Viewer visualising the different layers of BIM data

3.1.3. BIMy Augmented Reality Application

BIMy tackles the use of AR by considering a combined approach where BIM and GIS are interlinked. Unity plays a critical role as a catalyst for the visualisation of 3D BIM models. BIMy leverages the gaming industry visualisation knowledge and experience through Unity for AEC applications. BIMy effectively combines IFC OpenShell and BIMserver for model data management. IFC OpenShell is successfully implemented for BIM data in IFC 2x3 for-mat throughout the project.

In BIMy project, the AR technology is utilised in two different ways. First, AR is used to simply visualise the BIM and GIS content in its real environment by augmenting the building infrastructure data overlaid on the original scene. Second, AR is used to train residents in case of a disaster by presenting the dangerous zones and hazardous infrastructure, building components and assets in case of a fire or earthquake. For the AR-enabled BIM visualisation and evacuation scenario application, real settings are needed for users who are actually present in the ambiance where buildings with BIM models and assets are within sight. The following

snapshots in Figure 7 and Figure 8 are captured from the Hololens and mobile phone screen where AR is applied for two BIM models of real settings located in Skopje.

House A:

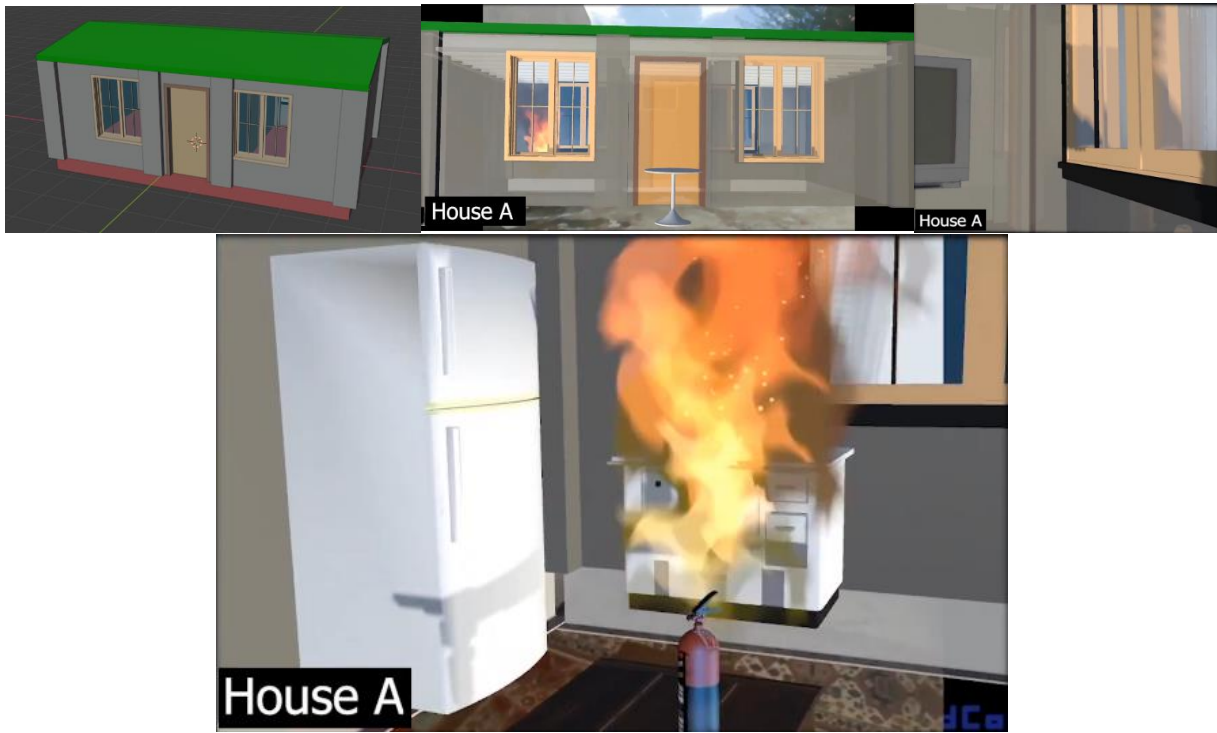

Figure 7. AR demonstration in House A.

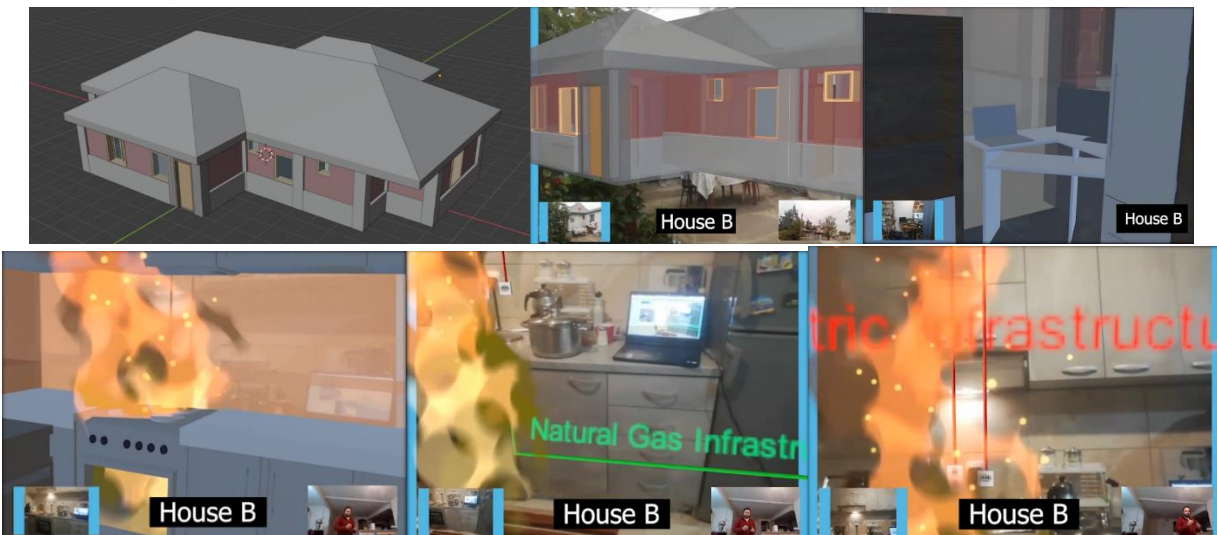

Figure 8. AR demonstration in House A.

3.1.4. BIM/GIS data transformer

The BIMy BIM/GIS data transformer is conceptually visualised in Figure 9. It takes as input LiDAR open data which gets transformed into roof structures constrained by GIM's Belmap based building footprint layer to derived Buildings in CityGML Level of Detail representation. The LiDAR data is also used to derive tree objects. The terrain model is extracted from an open data DTM. Cadastral parcels and road surface geometries are derived from GIMs Belmap product and finally subsoil infrastructure data is added that is made available in an INSPIRE conform GML model. Data is consolidated in the BIMy BIM/GIS integrated data model and from there on translated into IFC which is then imported into Revit and Solibri, into 3D tiles for display in the BIMy web viewer, into .obj files for AR visualisation and finally in datasmith files for use in the Unreal Gaming Engine.

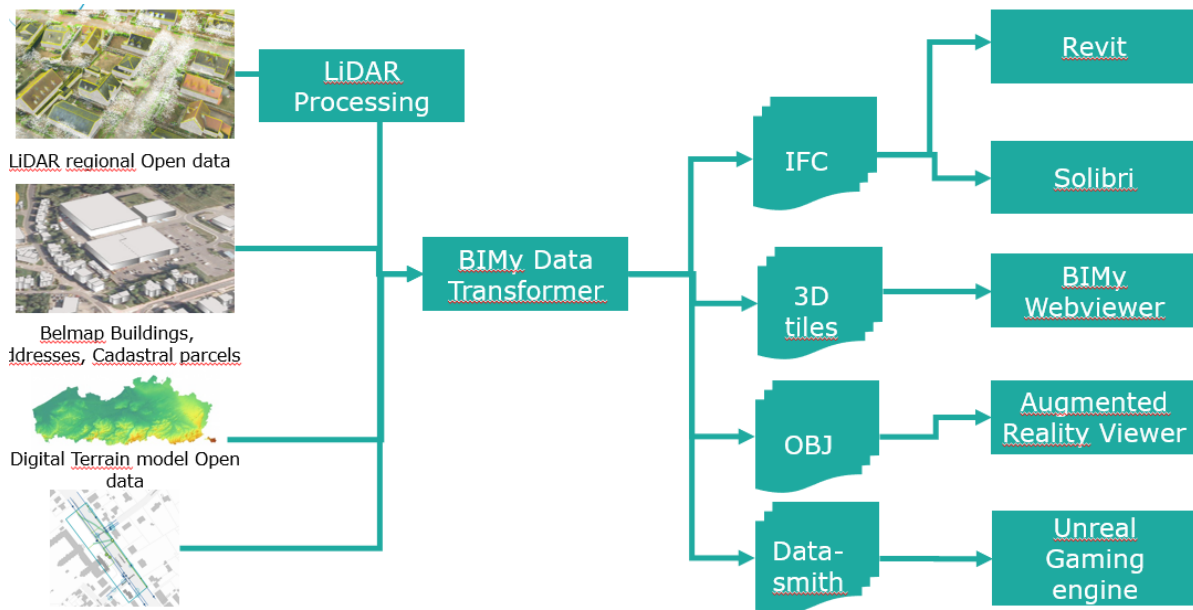

Figure 9. BIMy data transformer for urban context generation.

3.1.5. Fire Design Aid

The BIMy platform presents a link to a Fire Prevention App which is designed and built in Unity by ERARGE. The 3D BIM model is overlaid on the GIS environment surrounded by roads. The traffic intensity can be visualised instantly either by grabbing any sensory and camera data or simply traffic monitoring APIs provided by Google or Yandex. The various filters can be applied over the BIM data to visualise the building assets at different layers. The temperature, humidity and smoke data can be monitored as the online application enables MQTT platform to visualise any flowing IoT data. The safe and dangerous zones can also be presented for users to learn what to do in case of fire.

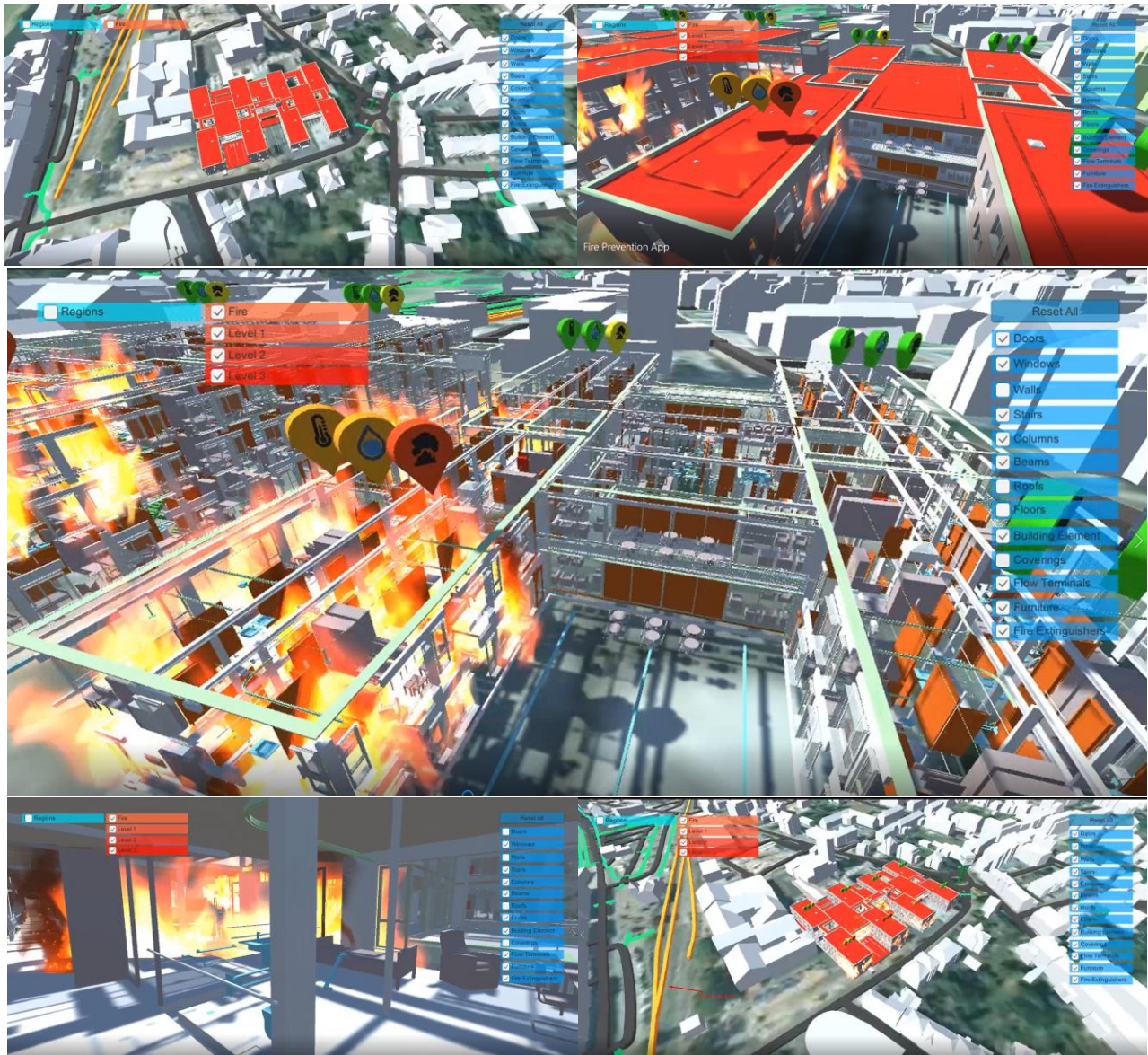

Figure 10. Some snapshots from the Fire Prevention App.

3.1.6. Long term vision - circular economy - urban mining

In a linear model, all the flows of building materials are known, from the mining site via the manufacturing plant to the construction site. The BIMy platform presents the urban mining results of an area, parcel or island in a city that is inspected for listing and estimating the recyclable elements of buildings. Figure 11 presents the Unity snapshot taken from a PC game which lists the number of buildings, windows and doors, estimated area of window glass, weight or volume of window and door materials, beam steel weight and volume, etc. Figure 12 presents the snapshots from the Web interface presenting the SPARQL query results in charts and graphics. This application is developed by ERARGE and NETAS.



Figure 11. Parcel-based BIM-GIS queries to filter recyclable materials in case these areas are decided to be demolished or transformed

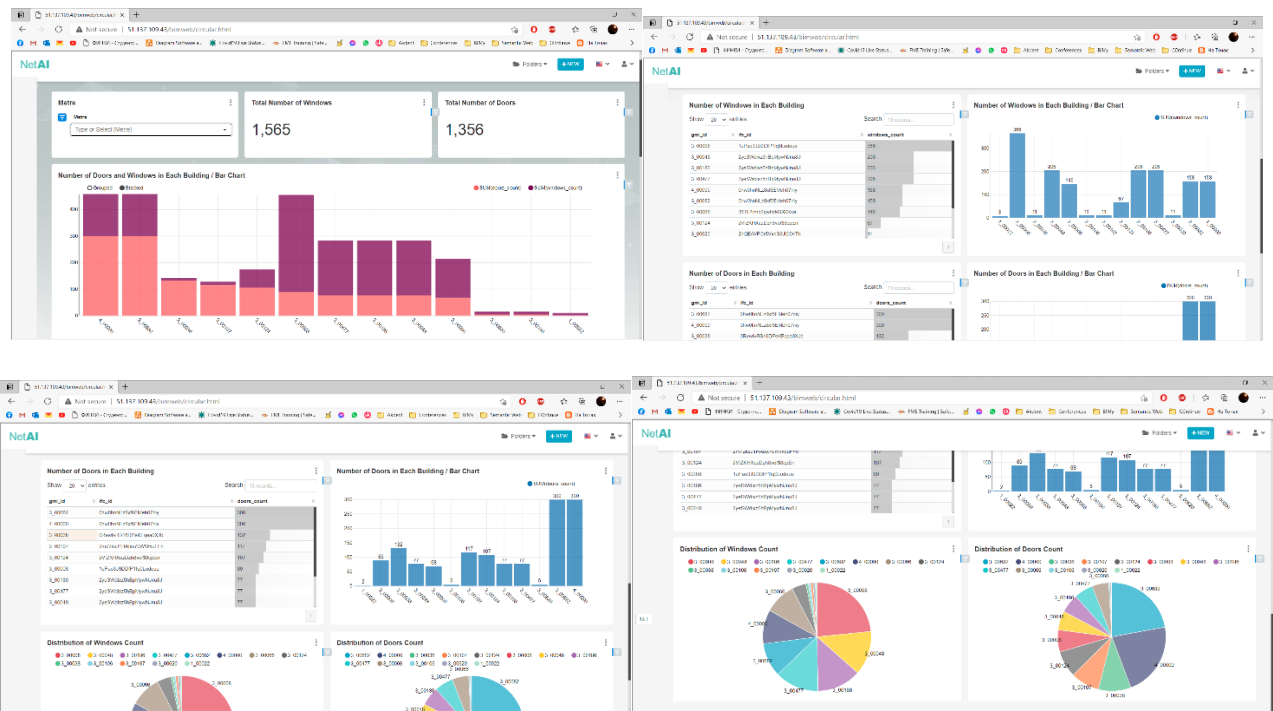

Figure 12. Some snapshots from the Web interface presenting the SPARQL query results in charts and graphics.

3.1.7. Digital Building Permit Application

It is usual that inspectors are required to carry out site inspections to ensure compliance with the building permit requirements. Similar challenges are found in this context, as inspectors normally do not have centralised and reliable access to all sources of information needed for an effective building permit inspection on site.

In this context, BIMy also leans on LetsBuild as a feasible on-site platform to bridge the information exchange. Inspectors have access to relevant BIM data on-site and are able to easily transmit inspection results to offsite project stakeholders. Inspectors can also utilise the platform to have a quick overview directly on the BIM model of the inspection tasks to be carried out, while also seeing a summary of all inspection tasks linked to a specific BIM object. Again, this workflow is reliant on object IDs to be successful, so it is necessary to look after the integrity of the objects IDs during models creation and management processes (Figure 13).

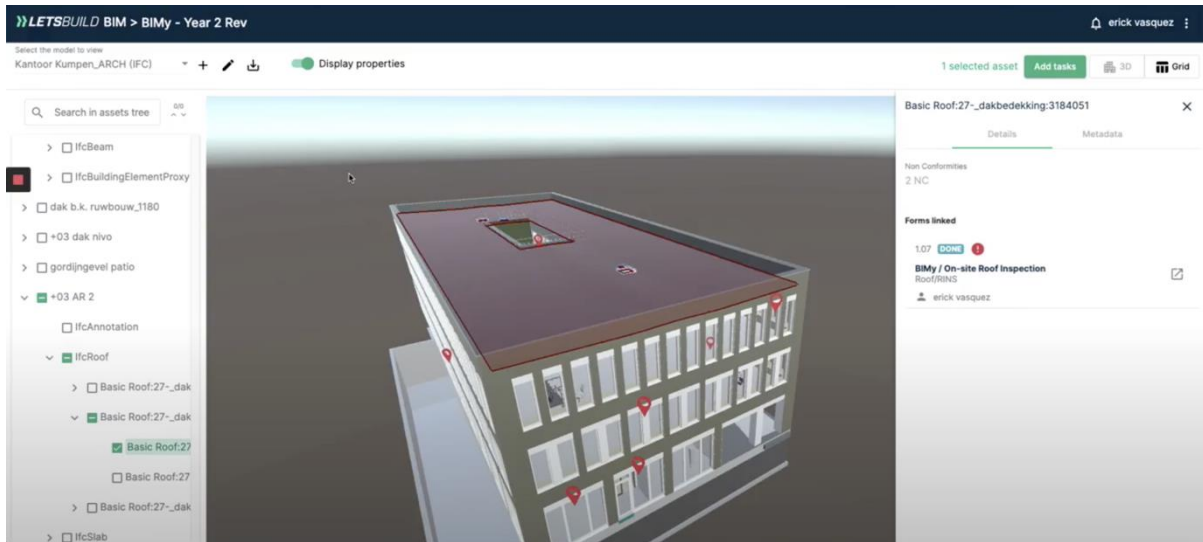

Figure 13. LetsBuild BIM module indicating BIM objects to inspect.

3.1.8. Disaster Simulation VR Training

This application is designed and built for the purpose of training residents against disasters to increase their awareness and preparedness for fires and earthquakes. The application is built for VR headsets, like Oculus Rift, by Unity. The Unity application is also built for PCs to deliver the application as a desktop game. This application was presented in Smart City Expo World Congress (SCEWC) 2019 (Barcelona). There was a huge interest to BIMy project and its VR-based interactive demonstration in SCEWC'19. This was evident from the statistics below. During the bilateral discussions at BIMy booth, visitors were informed about the project and asked them to try the VR application. Total time was recorded automatically by a backend timer for each VR session where volunteers started to test the application

- Number of visitors in SCEWC'19: 497
- Number of VR testers in SCEWC'19: 52
- Average time spent by each VR tester: 242 seconds

Some snapshots from the VR application are presented in Figure 14. This application is built by ERARGE.



Figure 14. Snapshots from the Disaster VR Training

3.1.9. Fire Prevention App

After the specifications and requirements for Fire Prevention have been established during the design phase, project stakeholder must ensure their compliance during the execution phase and further during the maintenance phase. To do so, inspectors carry out site inspections to verify information related to fire resistance of materials, evacuation routes, presence of equipment for fire-related emergencies, protection measures, etc. As such information should normally be included in BIM models, it would be ideal that inspectors have a reliable mechanism to access the relevant information supplied in the models. Further, to ensure that relevant project stakeholders are aware and can act about site inspection results, inspectors

should have an effective mechanism to provide inspection data back into BIM models, as they serve as a common shared source of truth. However, reality nowadays is that inspectors normally do not have the means to access the multiple relevant data sets neither have a reliable method to provide site inspection feedback into BIM models.

In this regard, BIMy leverages its interoperability capabilities by connecting with an on-site inspections platform (LetsBuild) and empowers project stakeholders by creating an effective bridge that facilitates data exchange for the fire inspection process. The bridge makes BIM metadata available in the on-site mobile application and allows inspection results to be sent accessible through a BIM model. This information exchange is done based on the IDs of BIM objects, native IDs in the case of models in native formats and GUIDs in the case of IFC models. For this reason, it is crucial to consider that the changes in object IDs would have an impact in such workflow.

The relevant BIM models are sent to the LetsBuild platform using a native plugin for Revit models or by means of direct upload for IFC models. In this platform, the user has access to the following functionalities to facilitate the fire inspection workflow:

- Different BIM Models of a project
- BIM objects metadata
- Library of customisable site form templates according to fire inspection standards
- Sets of project participants that can carry out inspection tasks
- Customisable work breakdown structure
- Library of project documents like 2D plans from the BIM model, reports, specifications, etc.

As seen in Figure 15, the user can then leverage these data sources to create site inspections that include BIM objects information, standards specifications in the form of checklist, technical documentation, assignees and more.

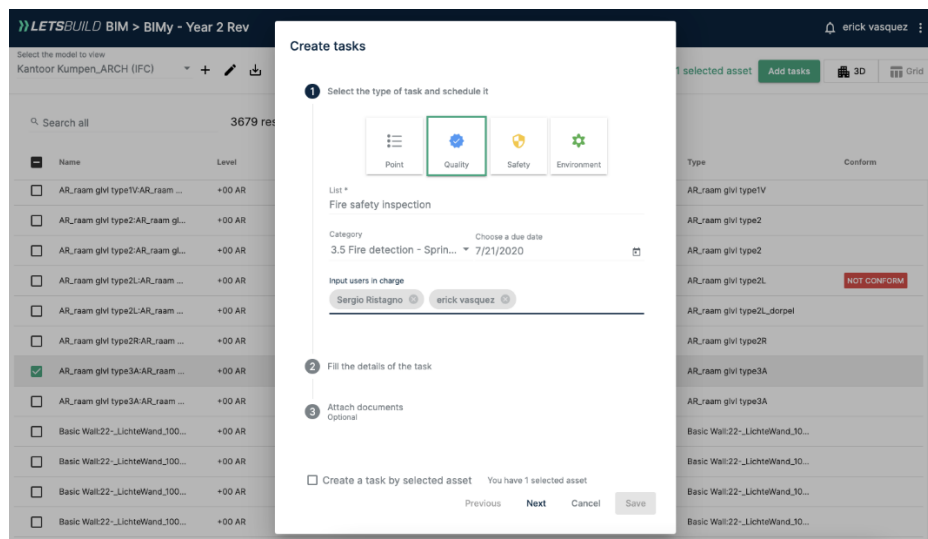

Figure 15. Using LetsBuild BIM module to create inspection tasks linking BIM models, checklists, assignees and more

Figure 16 presents site inspection details in a typical Revit object.

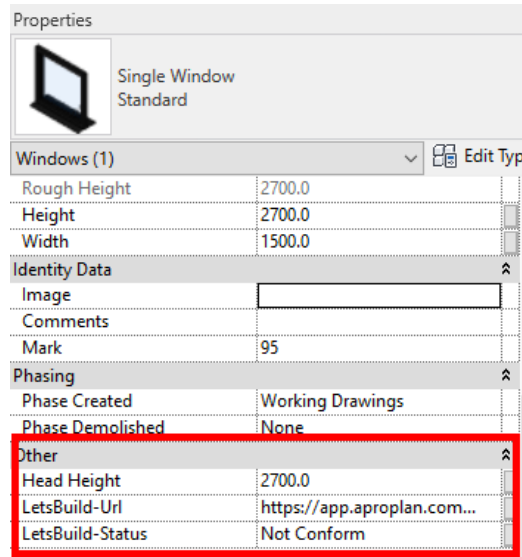
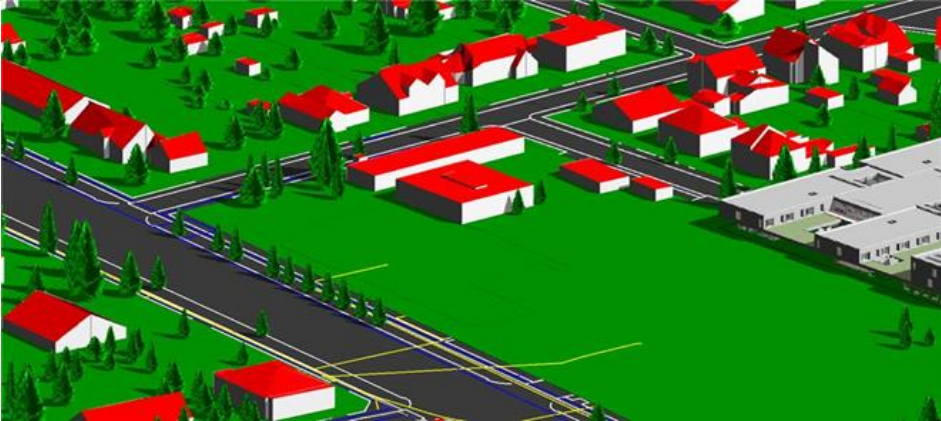

Figure 16. Site inspection details in Revit object.

3.2. Automatic generation of urban context for design and construction

Although not integrated in the BIMy platform, there exist outputs of joint studies which rely on the combined data models and the BIMy vision. The following demonstrator is designed and developed aiming to present an automatic generation of urban context for design and construction.

Name of the demonstrator	Automatic generation of urban context for design and construction
Link	https://youtu.be/uIPXlh_M8l0
Partners Contributing	<i>GIM, ASSAR, Willemen</i>
Responsible researcher(s) for technical discussions	Niels Gabriels, GIM NV, niels.gabriels@gim.be Steven Smolders, GIM NV, steven.smolders@gim.be
Description	<i>Obtain the Urban context for your construction site. With a click of a button, you can now have access to a complete 3D model of the project site and surroundings that is compatible with your favourite BIM modelling software and holds all the information you need to start designing: 3D elevation, trees, underground infrastructure, façades of surrounding buildings, etc.</i>
Targeted Audience	<i>Architects, Engineers, Urban planners</i>
Dissemination status	Public demonstration
Impact	<i>The urban context idea was discussed with architects, construction companies and urban planners inside and outside of the consortium. The production chain has</i>

	<p><i>undergone several iterations and 3 version of the product were demonstrated to and tested by the potential users.</i></p>
<p>Opinions & Feedback</p>	<ul style="list-style-type: none"> • <i>The Urban context file was generated was generated for the Kortrijk Care campus. It contains the surrounding buildings in GIS Level of Detail 2, the Digital Terrain Model, the cadastral parcels, the road surface geometry and the trees. This urban context was then delivered to BIM users inside and outside of the BIMy Consortium for their evaluation in several iterations. The following feedback was received:</i> • <i>Time savings: the generation through “digital labour” being manually designing of the Urban context is reduced from multiple days to hours.</i> • <i>There are notable improvements in terms of the accuracy of the positioning of the different objects.</i> • <i>The building reconstruction accuracy is generally enough for design purposes. For visualisation purposes, some further manual editing of the complexer buildings is required.</i> • <i>The inclusion of the trees and surrounding buildings facilitates design as well the planning of the construction site layout.</i> • <i>The inclusion of the subsoil infrastructure in the model is a definite plus in order to detect early on in the process design clashes and avoiding having to perform costly detours during the project.</i> • <i>Other datasets that would add value were identified:</i> <ul style="list-style-type: none"> ○ <i>Subsoil composition for foundation and drainage design</i> ○ <i>Inundation maps for drainage design</i> ○ <i>Street furniture and street surface layout.</i>
<p>Challenges Snapshots, Photos and Figures</p>	 <p><i>Urban context generated for the Kortrijk care campus – shown in Revit</i></p>

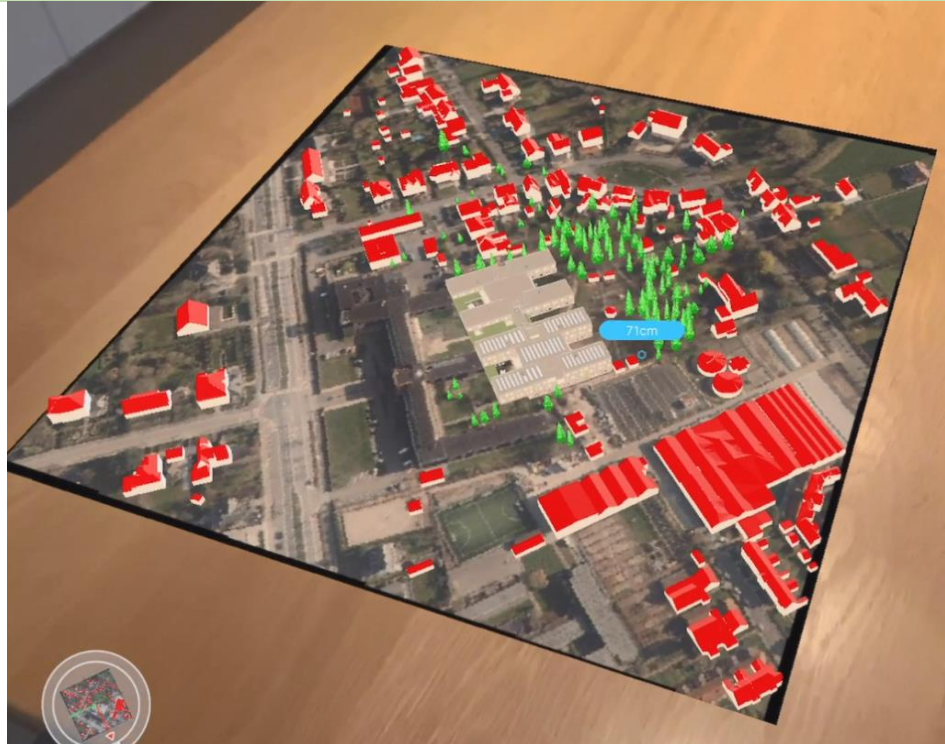

Urban context generated for the Kortrijk care campus – shown in Augmented Reality Viewer

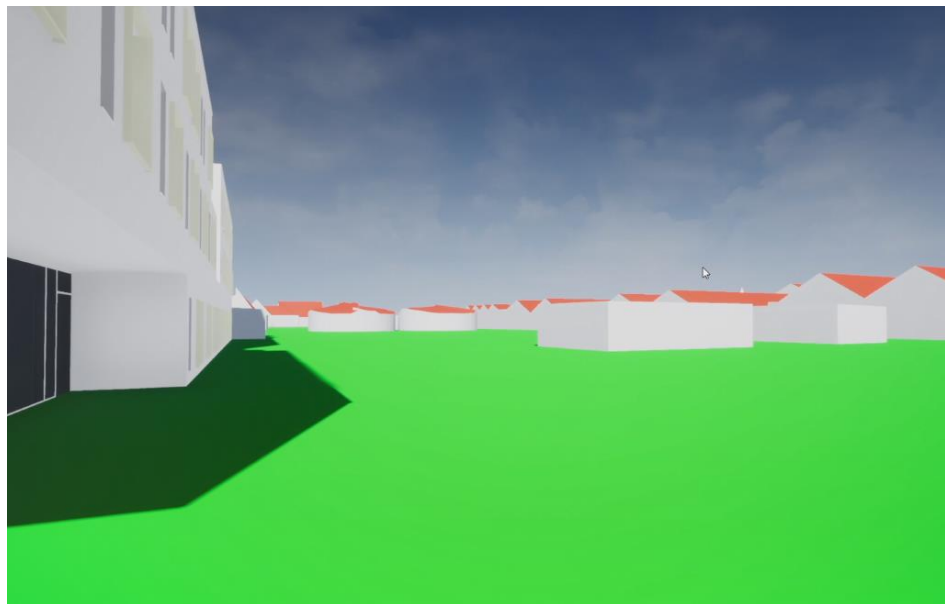

Urban context generated for the Kortrijk care campus – shown in Unreal gaming engine

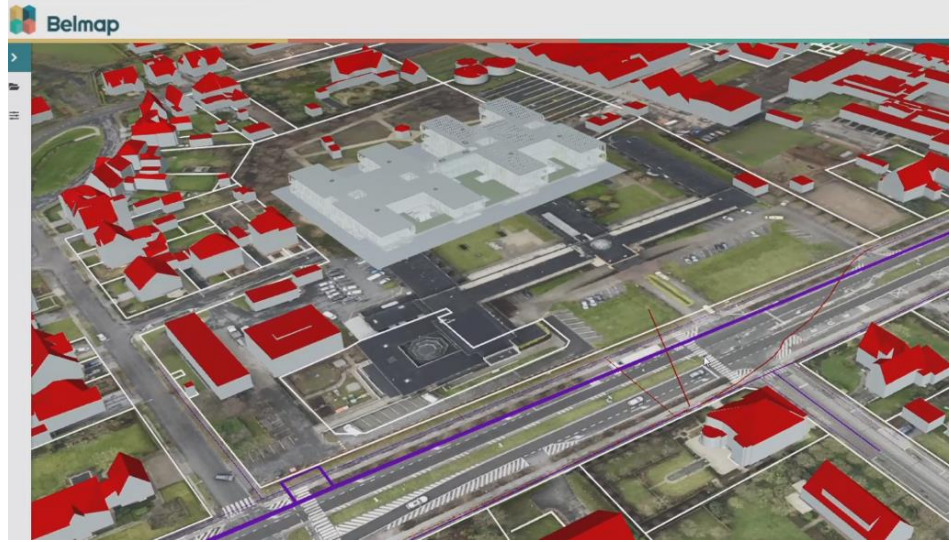

Urban context generated for the Kortrijk care campus – shown in Integrated BIM/GIS Web Viewer

3.3. Revit model checker – Naming Conventions Checkset

Name of the demonstrator	Revit model checker – Naming conventions checkset
Link	https://studio.youtube.com/video/I00BW0wtSX0/edit
Partners Contributing	Geo-IT
Responsible researcher(s) for technical discussions	Jens Lathouwers, Geo-IT, jens.lathouwers@geoit.be
Description	<i>Since an imported part of standardisation is to use consistent naming schemes in the models, the Autodesk Revit model checker was used to create a checkset that verifies the compliance with a chosen naming scheme. In the Demo the Belgian Revit standards naming scheme was used as a baseline for the check set.</i>
Targeted Audience	Architectss, designers, commissioning parties, contractors...
Dissemination status	Public demonstration
Impact	Geo-IT will use the gained knowledge to integrate in existing trainings, create new trainings and create custom check sets for customers. We're currently working on creating a Revit template which will be accompanied by a checkset to be used by parties who will work in this template.
Opinions & Feedback	The checksets have been shown in our webinar 'Bimmen met Revit'. We got a lot of interest from stakeholders throughout the whole building process.
Challenges	To exploit the model checker to its fullest potential there has to be a clear view on which classifications, and namings schemes will be used as reference. The changing standardisation landscape in Belgium could void the useability of some checks.
Snapshots, Photos and Figures	

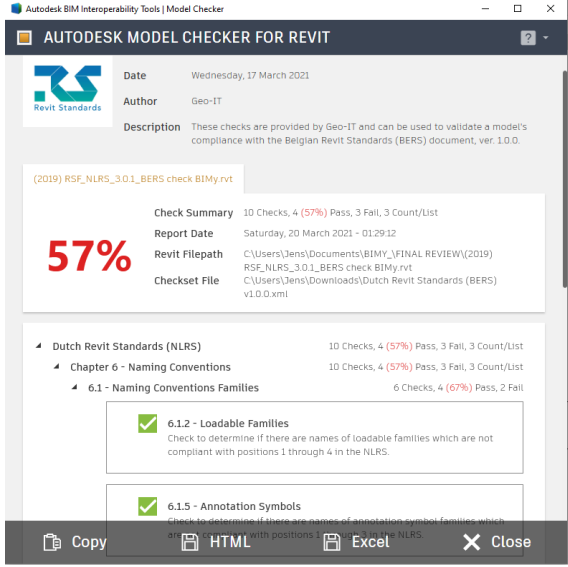

The screenshot displays the Autodesk Model Checker for Revit interface. The window title is "Autodesk BIM Interoperability Tools | Model Checker". The main header reads "AUTODESK MODEL CHECKER FOR REVIT".

Metadata:
Date: Wednesday, 17 March 2021
Author: Geo-IT
Description: These checks are provided by Geo-IT and can be used to validate a model's compliance with the Belgian Revit Standards (BERS) document, ver. 1.0.0.

Check Summary: 10 Checks, 4 (57%) Pass, 3 Fail, 3 Count/List
Report Date: Saturday, 20 March 2021 - 01:29:12
Revit Filepath: C:\Users\Jens\Documents\BIMy_FINAL REVIEW\2019\RSE_NLRS_3.0_1_BERS check BIMy.rvt
Checkset File: C:\Users\Jens\Downloads\Dutch Revit Standards (BERS) v1.0.0.xml

Compliance Summary:
Dutch Revit Standards (NLRs): 10 Checks, 4 (57%) Pass, 3 Fail, 3 Count/List
Chapter 6 - Naming Conventions: 10 Checks, 4 (57%) Pass, 3 Fail, 3 Count/List
6.1 - Naming Conventions Families: 6 Checks, 4 (67%) Pass, 2 Fail

6.1.2 - Loadable Families: [Pass] Check to determine if there are names of loadable families which are not compliant with positions 1 through 4 in the NLRs.

6.1.5 - Annotation Symbols: [Pass] Check to determine if there are names of annotation symbol families which are not compliant with positions 1 through 4 in the NLRs.

At the bottom, there are buttons for "Copy", "HTML", "Excel", and "Close".

4. Demonstrations & Trials – First Iteration (Year1 and ½ Year2)

Aligned with the use cases eleven online demonstrations, trials or exhibitions have been developed aiming to present a baseline for further extensions to a wider community. This section gives an overview of these demonstrators all of which have been planned and demonstrated mainly during the first (year) and second (year) iteration of the project.

Summary of the demonstrators and related use cases are given in Table 1.

Table 1. Summary of the Demonstrators

Type	UCS ID(s)	Demonstration	Lead	Team
Demo	10, 11	Demo 0. SCEWC 2019 demo https://youtu.be/ezLQqI0orkU	Erarge	Netas
Demo	ALL	Demo 1. BIMy Web Viewer integrated with BIMy API	GIM	Indirect contributions w.r.t. BIMy platform developments
Demo	7	Demo 2. Digital building permit on-site inspection set-up and execution https://youtu.be/7xbCRpocRz4	LetsBuild	Indirect contributions w.r.t. BIMy platform developments
Demo	7	Demo 3. BCF API for interoperability between BIMy and other BIM platforms (Technical) https://youtu.be/d5GZSEgqwZA	LetsBuild	Indirect contributions w.r.t. BIMy platform developments
Demo	10, 11, 14	Demo 4. VR Disaster Training Simulator https://youtu.be/s2QYIRiNrZc	Erarge	Assar
Demo	7	Demo 5. Revit model checker https://youtu.be/oyRASok7SIQ https://youtu.be/4bzk7oLsss8	Geo-IT	Indirect contributions w.r.t. BIMy platform developments
Demo	11	Demo 6. BIM-based minimal daylight criterion & acoustic insulation checks	BBRI	Indirect contributions w.r.t. BIMy platform developments
Vision	2	Demo 7. Long term vision – circular economy (concept)	Willemen	Aproplan, Assar, BBRI, CIRB, Geo-IT, Willemen
Demo + Vision	7	Demo 8. Digital building permit app	Sirris	Aproplan, Assar, BBRI, CIRB, Geo-IT, GIM, Willemen
Vision	8	Demo 9. Facilitate integration of urban context into BIM for architectural design	Assar	Willemen
Demo	ALL	Demo 10. Security demo https://youtu.be/kF4AEfqVLhE	Erarge	Netas

4.1. Demonstration (Demo-0) / BIMy in Smart City Expo World Congress (SCEWC) 2019, Barcelona

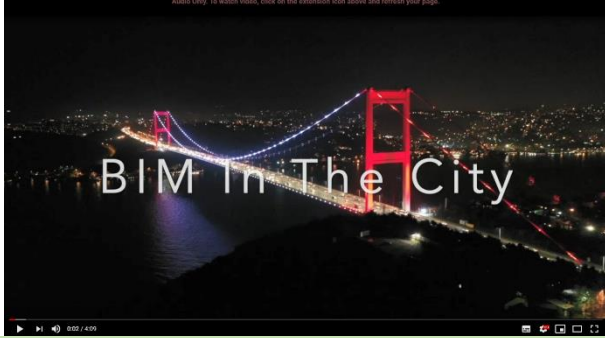
Name of the tool/Application/similar	BIMy in Smart City Expo World Congress (SCEWC) 2019, Barcelona
Link	https://youtu.be/ezLQgl0orkU 
Partners Contributing	ERARGE, NETAS
Responsible researcher(s) for technical discussions	<p>Alper KANAK Ph.D., ERARGE, alper.kanak@erarge.com.tr</p> <p>Osman Kumaş, NETAS, okumas@netas.com.tr</p> <p>Nagehan Çakır, NETAS, nagehanc@netas.com.tr</p>
Description	<p><i>This video presents the first-year achievements of BIMy, a EUREKA ITEA3 project with Project Nr. 16026. BIMy aims to integrate BIM and GIS models at semantic level and provides a cloud-based platform to utilise the well-known IFC and CityGML ontologies for smarter cities. This video presents an actual use of the integrated BIM-GIS framework and its use as a baseline for a VR-enabled simulation and training application. The VR application aims to increase the awareness of public in case of a disaster (earthquake or fire) occurs, help them to learn what to do or not to do during catastrophes, and prepare them to reach to the relief and assistance services in a city.</i></p>
Target Audience	<p><i>Expo participants including smart city experts, city authorities, first responder and relief organisation representatives, ICT experts, social innovators, investors, entrepreneurs, regular citizens or other potential contributors</i></p>
Dissemination status	Public demonstration
Statistics	<p><i>More than 500 participants were informed about BIMy in SCEWC'19. About 50 subjects tried the VR experience.</i></p>
Opinions & Feedback	<p><i>Nearly all visitors mentioned that they enjoyed the VR experience and shared their positive opinions about the BIMy idea. Although the demonstrated BIM cloud platform and the VR experience was reflecting the first steps, the visitors showed great interest. The idea of using BIM and GIS for critical infrastructure and surroundings protection, training of first responders, public awareness boosting by</i></p>

AR and VR, use of BIM in circular economy at urban transformation scale and the automation of building permit processes had been appreciated.

Some visitors also mentioned that if IoT and heterogeneous data processing and big data analytics improved the solution, BIMy could have a pioneering role in BIM-enabled smart city services. More effective transformation of old data formats (e.g. CAD) to BIM and standardisation of multilateral transformation of building and geophysical data formats was mentioned as the high potential extensions of BIMy in the smart city market.

Snapshots, Photos and Figures

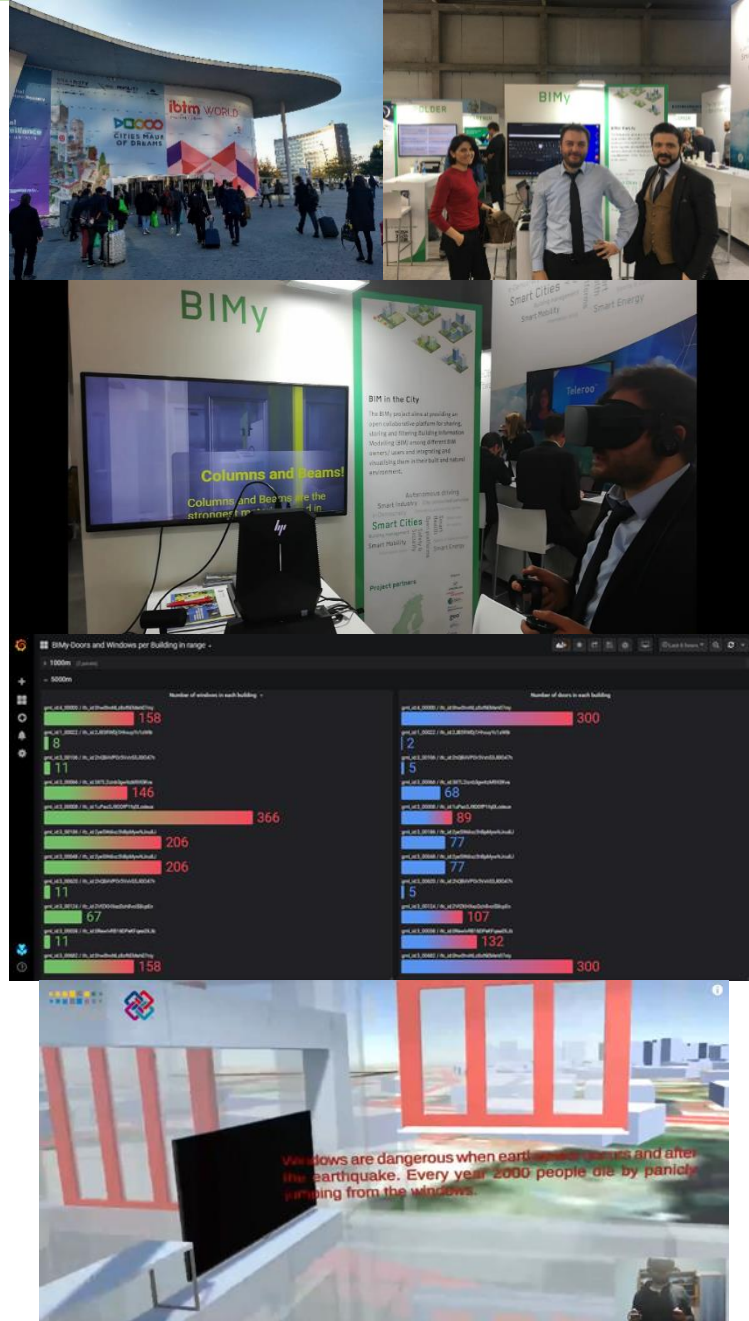

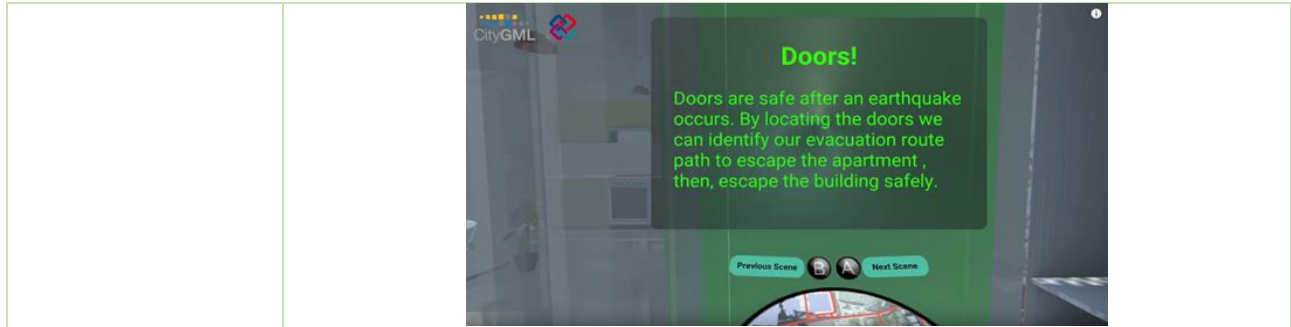

4.2. Demonstration (Demo1) / BIMy Web Viewer integrated with BIMy API

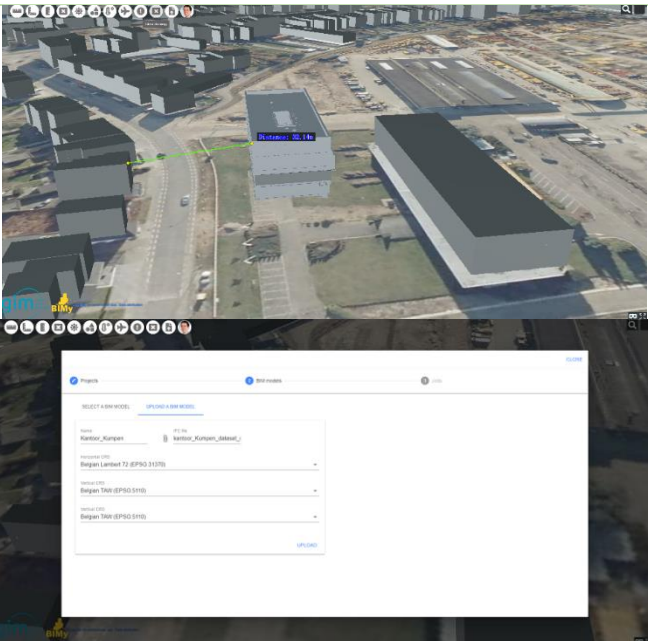
<p>Name of the tool/Application/ similar</p>	<p>BIMy Web Viewer integrated with BIMy API</p>				
<p>Link</p>	<p>https://www.youtube.com/watch?v=JX1dydKvRuM</p>				
<p>Partners Contributing</p>	<p>GIM</p>				
<p>Responsible researcher(s) for technical discussions</p>	<p>Stijn Goedertier, GIM Steven Smolders, GIM Niels Gabriels, GIM</p>				
<p>Description</p>	<p><i>Demonstrates connectivity with many other building blocks in the BIMy Platform.</i></p> <ul style="list-style-type: none"> ▪ <i>User stories:</i> <ul style="list-style-type: none"> ▪ <i>BIM data and GIS data according to BIMy Data Model: IFC, cadastral parcel, elevation model, ortho, building</i> ▪ <i>Authenticate using OAuth2</i> ▪ <i>Measure height, distance, surface</i> ▪ <i>Upload georeferenced BIM Model via BIMy API</i> ▪ <i>Create BCF topics</i> 				
<p>Target Audience</p>	<p><i>Use case: Digital Building Permit – Integrate BIM in urban context</i></p>				
<p>Dissemination status</p>	<p><i>Public</i></p>				
<p>Snapshots, Photos and Figures</p>	 <p>The image shows a 3D architectural rendering of a building complex with a grey facade and dark roof. A green dashed line indicates a measurement between two points on the building. Below the rendering is a software interface with a 'SELECT A BIM MODEL' section containing a table of data:</p> <table border="1"> <thead> <tr> <th>NAME</th> <th>FILE NO.</th> </tr> </thead> <tbody> <tr> <td>Kantoor_Kumpun</td> <td>Kantoor_Kumpun_000001_0</td> </tr> </tbody> </table> <p>Below the table are several dropdown menus for selecting model types, such as 'Bouwen Lokaal T2 (BPGD 31370)', 'Bouwen T2 (BPGD 31110)', and 'Bouwen T2 (BPGD 31110)'. An 'UPLOAD' button is visible at the bottom right of the interface.</p>	NAME	FILE NO.	Kantoor_Kumpun	Kantoor_Kumpun_000001_0
NAME	FILE NO.				
Kantoor_Kumpun	Kantoor_Kumpun_000001_0				



BIMy Platform API

The document describes how an application can use the API of the BIMy Platform. The BIMy API uses the OAuth2 Authorization code flow for authentication. Because all consortium members already have a GitHub account, it was decided that users of the API can authenticate on GitHub. In the future, other OAuth2 authentication providers could be added. To create an authentication session, you first need to request an authorization code on `oauth2/github/authorize` endpoint. `https://api.bimby.com/oauth2/github/authorize`. With the authorization code, an access token can be requested on the `oauth2/github/token` endpoint. See the documentation on the `OAuth2 Authorization code flow` for further documentation on the request parameters to use.

Terms of service
Contact the developer
© copyright BIMy consortium, 2019-2020
Web page of the BIMy project

Services

project Operations on project objects. See: <https://itea3.org/community/projects/bimby/bsaaca.html>

- POST** /project: add a new project on the BIMy platform
- GET** /project/{id}: Find projects a user has access to
- GET** /project/{projectId}: Get project by ID
- PUT** /project/{projectId}: Update a project
- DELETE** /project/{projectId}: Delete a project

model Operations on model objects. See: <https://itea3.org/community/projects/bimby/bsaaca.html>

- POST** /project/{projectId}/model: Upload (check-in) a BIM model for a project.
- GET** /model/{id}: Find all models the user has access to. Returns the model metadata, not the actual IFC.
- POST** /model/{query}: Query all models the user has access to. Returns a subset of the models' content. The results returned in the same format as the original model.
- GET** /project/{projectId}/model/{modelId}/(revisionId): Get the metadata of model by ID.
- PUT** /project/{projectId}/model/{modelId}/(revisionId): Update a BIM model for a project.
- DELETE** /project/{projectId}/model/{modelId}/(revisionId): Delete model by ID.
- POST** /project/{projectId}/model/{modelId}/(revisionId): Query a specific model the user has access to. Returns a subset of the models' content. The results returned in the same format as the original model.

job Operations to start long-running jobs on the BIMy platform. See: <https://itea3.org/community/projects/bimby/bsaaca.html>

- POST** /project/{projectId}/job: Generate job for a project.
- GET** /project/{projectId}/job/{id}: Find jobs a user has access to. Jobs can be running or completed.
- GET** /project/{projectId}/job/{jobId}: Get the status and results of a job by its job ID.

USER Operations on user objects. See: <https://itea3.org/community/projects/bimby/bsaaca.html>

- POST** /user/createWithInput: Create new users with given input array.
- GET** /user/{username}: Get user by username.
- PUT** /user/{username}: Update user.
- DELETE** /user/{username}: Delete user.

4.3. Demonstrator (Demo 2 & 3) / Digital building permit on-site inspection set-up and execution & BCF API for interoperability between BIMy and other BIM platforms

Name of the tool/Application/ similar	Digital building permit on-site inspection set-up and execution & BCF API for interoperability between BIMy and other BIM platforms
Link	<p>https://youtu.be/d5GZSEggwZA https://youtu.be/7xbCRpocRz4</p> <p>Content:</p> <ol style="list-style-type: none"> 1. Models management and tasks creation 2. Roof inspection set-up 3. Façade inspection set-up 4. Roof inspection execution 5. On-site inspections overview and results on BIM model
Partners Contributing	LetsBuild Aproplan
Responsible researcher(s) for technical discussions	<p>Olivier Gillin, LetsBuild olivier.gillin@letsbuild.com Erick Vasquez, LetsBuild erick.vasquez@letsbuild.com Sergio Ristagno, LetsBuild sergio.ristagno@letsbuild.com Daniel Pereira, LetsBuild daniel.pereira@letsbuild.com</p>
Description	<p>The videos and photos indicated here illustrate the collaboration and interoperability capabilities of the LetsBuild BIM Prototype. LetsBuild BIM Prototype acts as a tool to facilitate on-site utilisation of BIM data, as well as a medium to provide on-site activities updates back to Common Data Environments. In the context of BIMy, LetsBuild is targeting at substracting information of BIM models coming from the BIMy platform and connecting on-site inspection data to those.</p> <p>Considering that LetsBuild operates as an independent application, it is being developed to operate in an OpenBIM environment, currently supporting IFC models and soon supporting BCF issues.</p> <p>The prototype is aimed at supporting the digital building permit use case.</p> <ul style="list-style-type: none"> • Create inspections according to digital building permit details coming from the BIMy platform. • Provide efficient interfaces for on-site inspections (allow the attachment of annotations, pictures and documents to BIM objects) • Send on-site inspection results back to the BIMy platform as BCF topics.

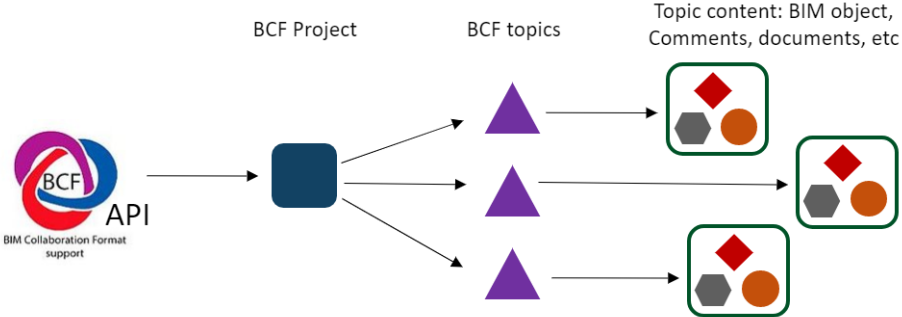
	 <p>The diagram illustrates the BCF API workflow. It starts with the BCF API (BIM Collaboration Format support) on the left, which connects to a central BCF Project. From the BCF Project, three arrows point to three separate BCF topics. Each BCF topic then points to a box representing topic content, which includes BIM objects, comments, and documents. The BCF logo is also present on the left side of the diagram.</p>
<p>Target Audience</p>	<p><i>Existing clients and business leads</i></p> <ul style="list-style-type: none"> • <i>Architects, engineers and designers</i> • <i>Project promoters</i> • <i>Main contractors and subcontractors</i> • <i>Facility managers</i> • <i>Project promoters and clients</i> <p><i>BIMy consortium members</i></p>
<p>Dissemination status</p>	<p>Public demonstration</p>
<p>Statistics</p>	<p><i>Number of demonstrations to existing clients and business leads: 52</i></p> <p><i>Number of users currently enrolled for testing: 24</i></p> <p><i>Number of pending requests for testing: 7</i></p>
<p>Opinions & Feedback</p>	<p><i>Most clients and business leads are interested about the functionalities of the LetsBuild BIM prototype. The prototype facilitates the understanding of the utilisation of BIM models on site for inspections and issues management. In regards to the BIMy project specifically, demonstrations have illustrated the potential for collaboration by using LetsBuild as a complementary platform for on-site activities. The array of features and functionalities already existing in LetsBuild facilitate the implementation of on-site workflows related to the use cases of the BIMy project (Digital building permit, fire inspection, etc). Having an OpenBIM approach has been highlighted as crucial by many users, reason why the existing support for IFC models and the future development of BCF functionalities for issues management in the BIM prototype have been well perceived.</i></p> <p><i>Nonetheless, clients, business leads and BIMy consortium members have highlighted a few limitations of the BIM prototype: a) The 3D viewer is in early phases of development and needs more robust navigation and features. b) The 3D viewer is only available on the web version. Despite being integrated with the mobile on-site workflows of LetsBuild, users are looking forward to using the 3D model in mobile devices. c) Issues management and inspection workflows are powerful, but users would like to see extended functionalities for other construction processes (Planning, progress reports, quantity surveying, etc).</i></p>

Snapshots, Photos and Figures



LetsBuild Web 3D viewer indicating BIM objects linked to inspections

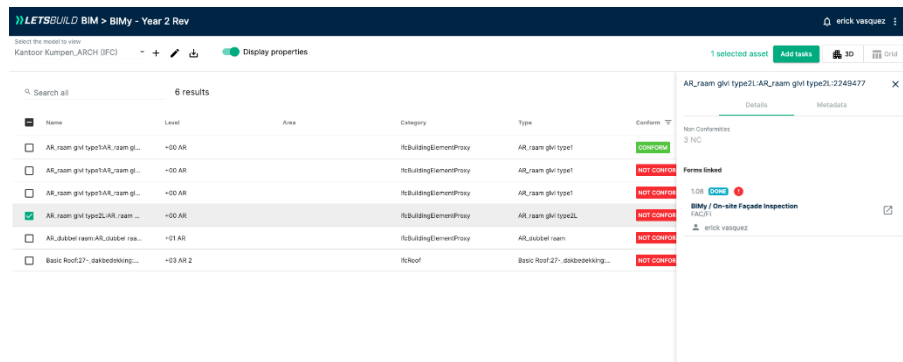

LetsBuild BIM module to manage inspections linked to BIM objects

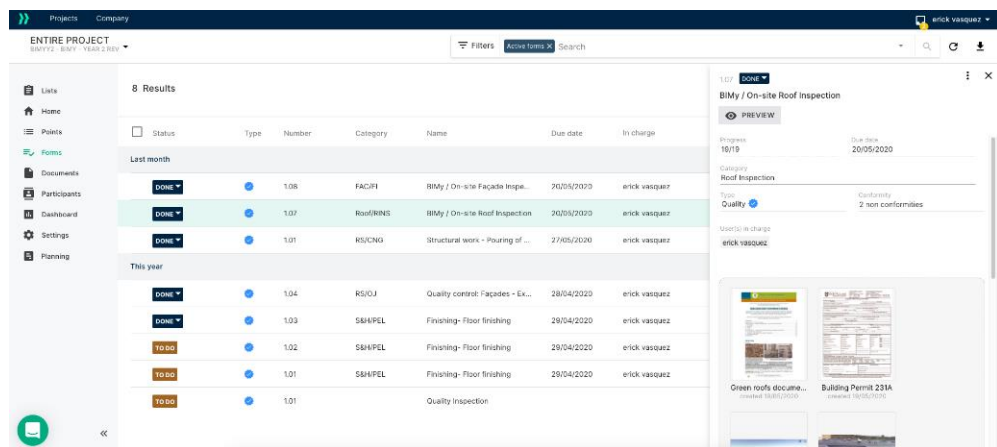

LetsBuild Web to manage assigned inspections

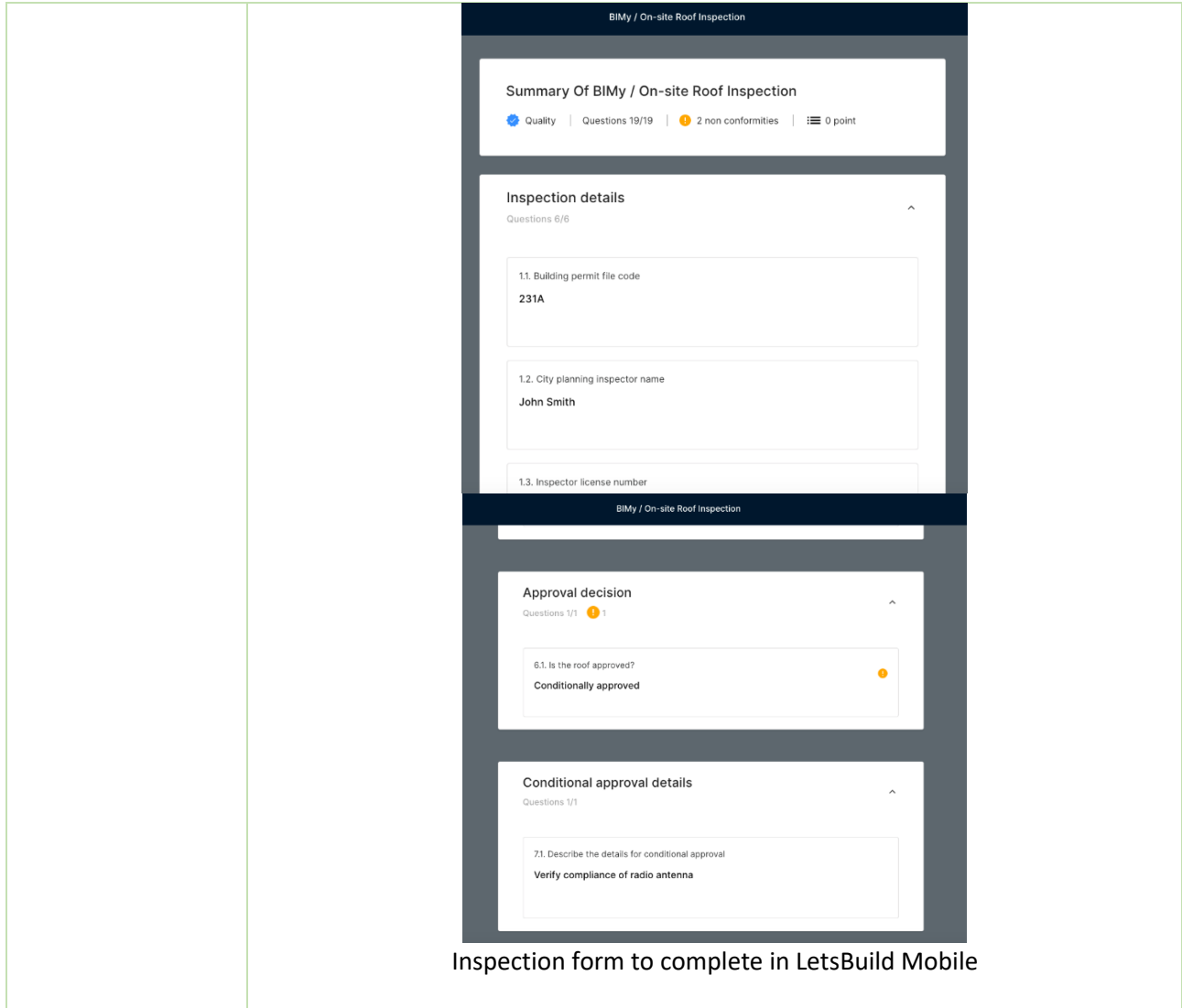

The screenshot displays a mobile application interface for an inspection form. At the top, a dark blue header reads "BIMy / On-site Roof Inspection". Below this is a white summary box titled "Summary Of BIMy / On-site Roof Inspection" containing a progress bar with icons for "Quality", "Questions 19/19", "2 non conformities", and "0 point".

The main section is titled "Inspection details" and shows "Questions 6/6". It contains three input fields:

- 1.1. Building permit file code: 231A
- 1.2. City planning inspector name: John Smith
- 1.3. Inspector license number: (empty)

A second dark blue header also reads "BIMy / On-site Roof Inspection". Below it is a white box titled "Approval decision" showing "Questions 1/1" and a yellow warning icon. It contains a question: "6.1. Is the roof approved?" with the answer "Conditionally approved" and a yellow dot.

The final section is titled "Conditional approval details" and shows "Questions 1/1". It contains a question: "7.1. Describe the details for conditional approval" with the answer "Verify compliance of radio antenna".

Inspection form to complete in LetsBuild Mobile

4.4. Demonstrator (Demo 4) / VR Disaster Training Simulator

Name of the tool/Application/ similar	VR Disaster Training Simulation
Link	https://youtu.be/s2QYIRiNrZc
Partners Contributing	ERARGE, ASSAR, NETAŞ
Responsible researcher(s) for technical discussions	Alper KANAK Ph.D., ERARGE, alper.kanak@erarge.com.tr Ibrahim ARIF, ERARGE, ibrahim.arif@erarge.com.tr Thomas GOOSSENS, ASSAR, tgo@assar.com
Description	<p>An intermediary demo, as a result of joint study between ERARGE and ASSAR Architects in BIMy.</p> <p>The simulation effectively uses the BIMy platform by extracting virtual 3D layers with pre-queries. Semi-automatic content adaptation is applied by following these steps:</p> <ul style="list-style-type: none"> • Information model is retrieved by BIMy queries (what to be presented) • Models generated in ifc format • Ifc formats parsed into .dae format (automatic parser-dockerised). • Dae file saved on BIMy simulation folder. • Dae file imported to Unity (dockerised) • Dae file parsed elements by name and materialised and becomes prefab (automatic alignment and renaming for better organisation of BIM & GIS content) • Props and Scenarios are created, refined (by development over Unity).
Target Audience	Municipalities, city planners, disaster trainees, fire brigade
Dissemination status	Public demonstration
Opinions & Feedback	Positive thoughts from consortium partners were shared, whilst additional improvements on the simulation were offered during the development.
Snapshots, Photos and Figures	 <p>The solution is elastic to create dynamic *.dae layers associated with</p>

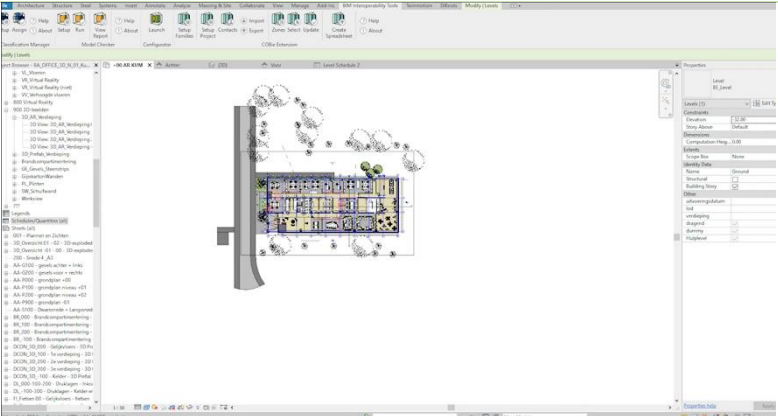

4.5. Demonstrator (Demo 5) / Revit model checker

Name of the tool/Application/ similar	Revit model checker
Link	https://youtu.be/oyRASok7SIQ https://youtu.be/4bzk7oLsss8
Partners Contributing	<i>Geo-IT, BIMy platform contributors</i>
Responsible researcher(s) for technical discussions	<i>Jens Lathouwers, Geo-IT, jens.lathouwers@geoit.be</i>
Description	<p><i>In the current situation, there's no widespread standardisation, and there's no efficient way to check models on compliance with a bim protocol. From the beneficial aspect, the Revit model checker can be provided, together with a standardisation method and modelling guidelines to give either the creator of the model, or the receiving party the possibility to check the compliance between those three documents.</i></p>
Target Audience	<i>Architects, designers</i>
Dissemination status	Public demonstration
Opinions & Feedback	<p><i>The following months the knowledge gained by working on the building permit use-case will be exploited to apply it to create a check-set for the fire regulation use case.</i></p> <p><i>The exported xml from the check should be exchangeable between the Revit model checker and the Bimy platform to use the same checks on both sides of the regulations.</i></p>
Snapshots, Photos and Figures	

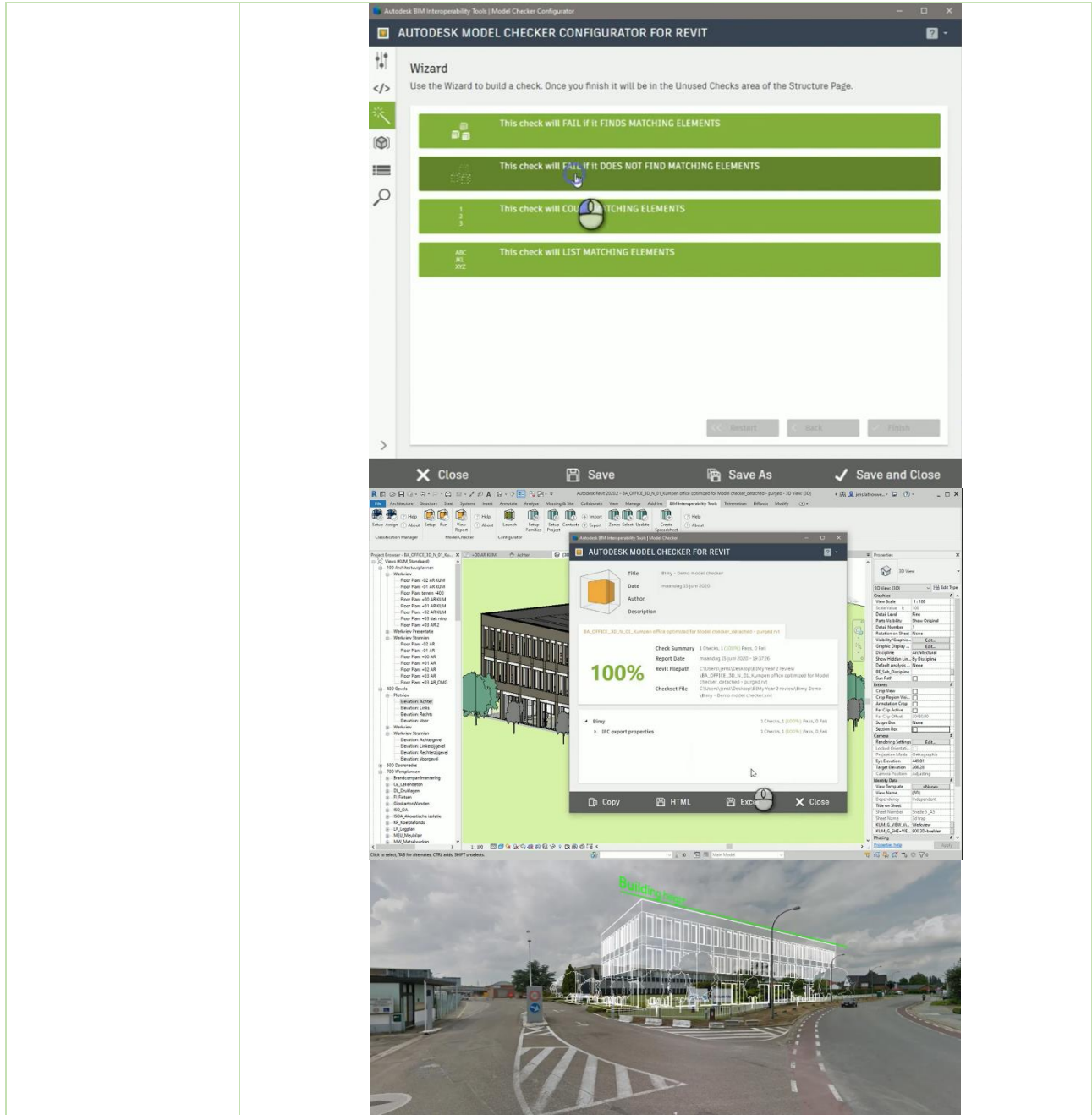

4.6. Demonstrator (Demo 6) / BIM-based minimal daylight criterion & acoustic insulation checks

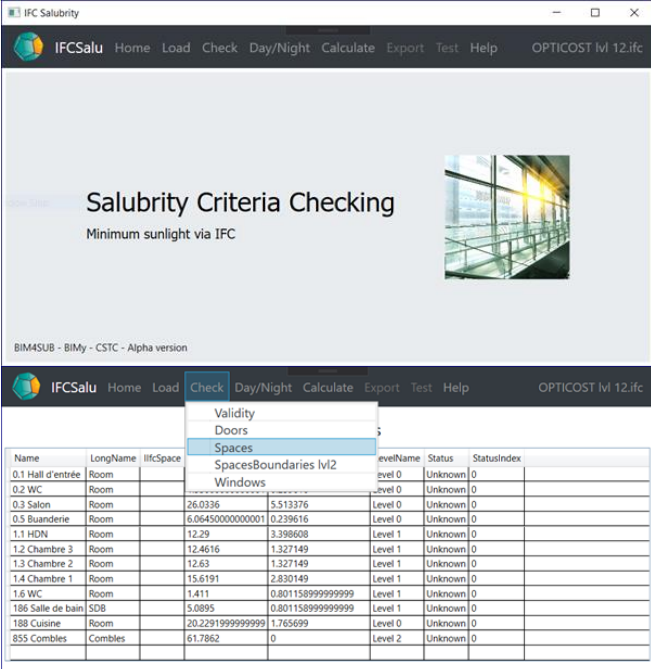
Name of the tool/Application/ similar	IFC Salubrity Criteria Checking application																																																																																												
Link	NA																																																																																												
Partners Contributing	BBRI, Sirris																																																																																												
Responsible researcher(s) for technical discussions	Robberts François, BBRI, francois.robberths@bbri.be																																																																																												
Description	The application is based on the Order of the Walloon Government of 30 August 2007. It allows to verify one of the salubrity criteria presented by the document: the criterion of minimum natural lighting. To do this, the program extracts from an IFC file the necessary data available and allows the user to check the conformity of the model with the rules in effect.																																																																																												
Target Audience	Government authorities auditing this criterion, and entities subject to the audit																																																																																												
Dissemination status	Public demonstration <i>Consortium only</i>																																																																																												
Snapshots, Photos and Figures	 <table border="1" data-bbox="643 1398 1289 1608"> <thead> <tr> <th>Name</th> <th>LongName</th> <th>IFCSpace</th> <th>SpacesBoundaries lvl2</th> <th>levelName</th> <th>Status</th> <th>StatusIndex</th> </tr> </thead> <tbody> <tr> <td>0.1 Hall d'entrée</td> <td>Room</td> <td></td> <td></td> <td>level 0</td> <td>Unknown</td> <td>0</td> </tr> <tr> <td>0.2 WC</td> <td>Room</td> <td></td> <td></td> <td>level 0</td> <td>Unknown</td> <td>0</td> </tr> <tr> <td>0.3 Salon</td> <td>Room</td> <td>26.0336</td> <td>5.513376</td> <td>Level 0</td> <td>Unknown</td> <td>0</td> </tr> <tr> <td>0.5 Buanderie</td> <td>Room</td> <td>6.06450000000001</td> <td>0.239616</td> <td>Level 0</td> <td>Unknown</td> <td>0</td> </tr> <tr> <td>1.1 HDN</td> <td>Room</td> <td>12.29</td> <td>3.398608</td> <td>Level 1</td> <td>Unknown</td> <td>0</td> </tr> <tr> <td>1.2 Chambre 3</td> <td>Room</td> <td>12.4616</td> <td>1.327149</td> <td>Level 1</td> <td>Unknown</td> <td>0</td> </tr> <tr> <td>1.3 Chambre 2</td> <td>Room</td> <td>12.83</td> <td>1.327149</td> <td>Level 1</td> <td>Unknown</td> <td>0</td> </tr> <tr> <td>1.4 Chambre 1</td> <td>Room</td> <td>15.6191</td> <td>2.830149</td> <td>Level 1</td> <td>Unknown</td> <td>0</td> </tr> <tr> <td>1.6 WC</td> <td>Room</td> <td>1.411</td> <td>0.8011589999999999</td> <td>Level 1</td> <td>Unknown</td> <td>0</td> </tr> <tr> <td>186 Salle de bain</td> <td>SDB</td> <td>5.0895</td> <td>0.8011589999999999</td> <td>Level 1</td> <td>Unknown</td> <td>0</td> </tr> <tr> <td>188 Cuisine</td> <td>Room</td> <td>20.22919999999999</td> <td>1.765699</td> <td>Level 0</td> <td>Unknown</td> <td>0</td> </tr> <tr> <td>855 Combles</td> <td>Combles</td> <td>61.7862</td> <td>0</td> <td>Level 2</td> <td>Unknown</td> <td>0</td> </tr> </tbody> </table>		Name	LongName	IFCSpace	SpacesBoundaries lvl2	levelName	Status	StatusIndex	0.1 Hall d'entrée	Room			level 0	Unknown	0	0.2 WC	Room			level 0	Unknown	0	0.3 Salon	Room	26.0336	5.513376	Level 0	Unknown	0	0.5 Buanderie	Room	6.06450000000001	0.239616	Level 0	Unknown	0	1.1 HDN	Room	12.29	3.398608	Level 1	Unknown	0	1.2 Chambre 3	Room	12.4616	1.327149	Level 1	Unknown	0	1.3 Chambre 2	Room	12.83	1.327149	Level 1	Unknown	0	1.4 Chambre 1	Room	15.6191	2.830149	Level 1	Unknown	0	1.6 WC	Room	1.411	0.8011589999999999	Level 1	Unknown	0	186 Salle de bain	SDB	5.0895	0.8011589999999999	Level 1	Unknown	0	188 Cuisine	Room	20.22919999999999	1.765699	Level 0	Unknown	0	855 Combles	Combles	61.7862	0	Level 2	Unknown	0
Name	LongName	IFCSpace	SpacesBoundaries lvl2	levelName	Status	StatusIndex																																																																																							
0.1 Hall d'entrée	Room			level 0	Unknown	0																																																																																							
0.2 WC	Room			level 0	Unknown	0																																																																																							
0.3 Salon	Room	26.0336	5.513376	Level 0	Unknown	0																																																																																							
0.5 Buanderie	Room	6.06450000000001	0.239616	Level 0	Unknown	0																																																																																							
1.1 HDN	Room	12.29	3.398608	Level 1	Unknown	0																																																																																							
1.2 Chambre 3	Room	12.4616	1.327149	Level 1	Unknown	0																																																																																							
1.3 Chambre 2	Room	12.83	1.327149	Level 1	Unknown	0																																																																																							
1.4 Chambre 1	Room	15.6191	2.830149	Level 1	Unknown	0																																																																																							
1.6 WC	Room	1.411	0.8011589999999999	Level 1	Unknown	0																																																																																							
186 Salle de bain	SDB	5.0895	0.8011589999999999	Level 1	Unknown	0																																																																																							
188 Cuisine	Room	20.22919999999999	1.765699	Level 0	Unknown	0																																																																																							
855 Combles	Combles	61.7862	0	Level 2	Unknown	0																																																																																							

IFCSalu Home Load Check Day/Night Calculate Export Test Help
OPTICOST Ivl 12.ifc

Caractérisation des pièces

0.1 Hall d'entrée	Day Room
0.2 WC	Not a Living Room
0.3 Salon	Day Room
0.5 Buanderie	Not a Living Room
1.1 HDN	Day Room
1.2 Chambre 3	Night Room
1.3 Chambre 2	Unknown

IFCSalu Home Load Check Day/Night Calculate Export Test Help
OPTICOST Ivl 12.ifc

Criteria of Calculation

Type of building: Existing Building

	Day Room	Night Room
Minimum (Vertical Glass Area) / (Room Area)	1/14	1/14
Minimum (Roof Glass Area) / (Room Area)	1/16	1/16

IFCSalu Home Load Check Day/Night Calculate Export Test Help
OPTICOST Ivl 12.ifc

Résultats

Name	SquareMeterArea	SquareMeterGlassArea	LevelName	Status	Ratio	Evaluation
0.1 Hall d'entrée	3.529500000000002	0	Level 0	Not a Living Room	0	For info
0.2 WC	1.530000000000001	0.239616	Level 0	Not a Living Room	1.87934117647058	For info
0.3 Salon	26.0336	5.513376	Level 0	Day Room	2.54135086964538	Ok
0.5 Buanderie	6.064500000000001	0.239616	Level 0	Not a Living Room	0.474135048231511	For info
1.1 HDN	12.29	3.398608	Level 1	Night Room	3.3184130187144	Ok
1.2 Chambre 3	12.4616	1.327149	Level 1	Night Room	1.27798902227643	Ok
1.3 Chambre 2	12.63	1.327149	Level 1	Night Room	1.26094916864608	Ok
1.4 Chambre 1	15.6191	2.830149	Level 1	Night Room	2.17437547617981	Ok
1.6 WC	1.411	0.801158999999999	Level 1	Not a Living Room	6.81354216867469	For info
186 Salle de bain	5.0895	0.801158999999999	Level 1	Not a Living Room	1.88896905393457	For info
188 Cuisine	20.2291999999999	1.765699	Level 0	Day Room	1.04741601249679	Ok
855 Combles	61.7862	0	Level 2	Not a Living Room	0	For info

4.7. Vision (Vision 7) / Long term vision – circular economy (concept)

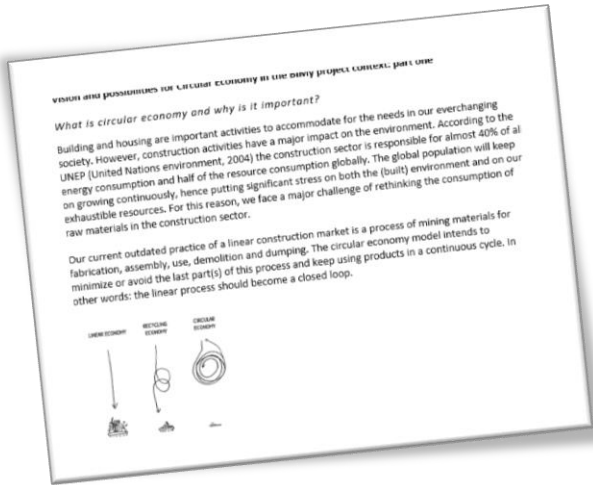
Name of the tool/Application/ similar	Circular Economy: Long term Vision – Online article in two parts
Link	<i>Web link to article to be added after publication</i>
Partners Contributing	<i>Willemen, Assar, GIM</i>
Responsible researcher(s) for technical discussions	<i>Hashmat Wahid, Willemen, Hashmat.wahid@willemen.be Dieter Froyen, Willemen, dieter.froyen@willemen.be Lise Bibert, Willemen, lise.bibert@willemen.be</i>
Description	<i>Article explaining the possibilities for applications regarding Circular Economy in the long term on the BIMy platform and the limitations that prevent current exploitation that need to be overcome. Includes a conceptual demo video of a future possible application.</i>
Target Audience	<i>Construction companies in the broadest sense of the word Manufacturers of construction materials Government or consulting bodies imposing BIM or building regulation Any other parties that have an interest in Circular Economy</i>
Motivation	<i>This article could create spirit with the target audience to contribute to better or more standardised workflows, agreements or requirements.</i>
Dissemination status	<i>Public demonstration (not yet published)</i>
Snapshots, Photos and Figures	

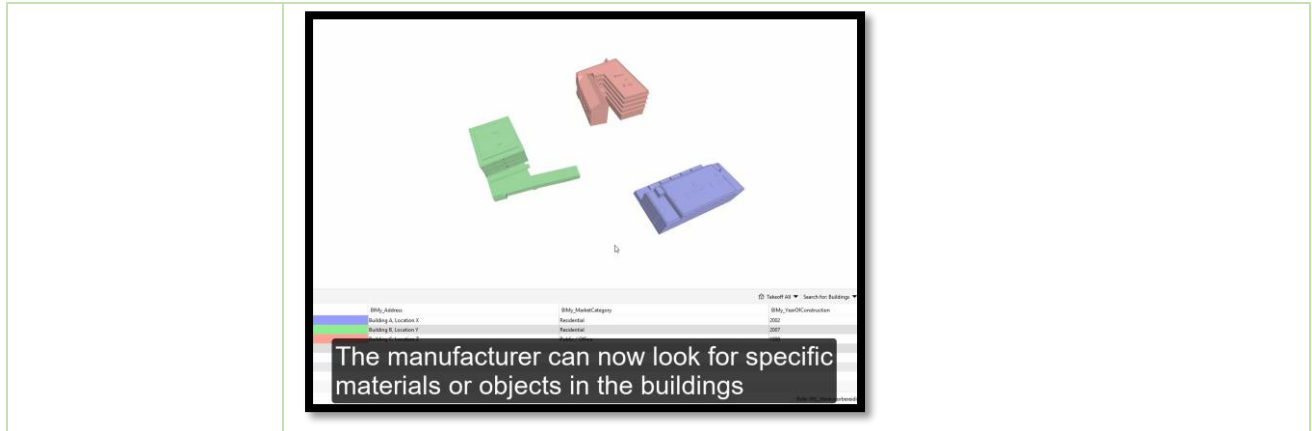

4.8. Demonstration and Vision (8) / Digital building permit app

Requesting a building permit can be a tedious administrative task, in which information is often duplicated and later lost. This demonstrator shows how the process could be simplified/streamlined using a digital Building Permit Application supported by the BIMy platform.

The application is developed as a collaboration between all consortium partners. It highlights the different individual contributions, but also demonstrates a complete proof of concept of the BIMy platform. The motivation behind this vision is that the inclusion of BIM (or BIMy) in mandatory public processes such as building permit requests could be a catalyst for widespread adoption.

Name of the tool/Application/similar	Building Permit Application (Evacuation in case of a disaster)
Link	https://drive.google.com/file/d/1I_cXgDNVPjKJXEQa9OcgP0OxFu88Z0yW/view
Partners Contributing	ASSAR, BBRI, ERARGE, Geo-IT, GIM, Letsbuild, NETAS, Sirris, Willemen
Responsible researcher(s) for technical discussions	Olivier Biot, Sirris, olivier.biot@sirris.be Stijn Goedertier, GIM, stijn.goedertier@gim.be Steven Smolders, GIM, steven.smolders@gim.be Thomas Goossens, ASSAR, tgo@assar.com François Robberts, BBRI, francois.robberts@bbri.be Erick Vasquez, Letsbuild, Erick.vasquez@letsbuild.com
Description	<p>Requesting a building permit can be a tedious administrative task, in which information is often duplicated and later lost. This demonstrator shows how the process could be simplified/streamlined using a digital Building Permit Application supported by the BIMy platform.</p> <p>The application is developed as a collaboration between all consortium partners. It highlights the different individual contributions, but also demonstrates a complete proof of concept of the BIMy platform.</p>
Target Audience	Architects, city planners, building owners
Motivation	The inclusion of BIM (or BIMy) in mandatory public processes such as building permit requests could be a catalyst for widespread adoption.
Dissemination status	Currently: Consortium only Later: public demonstrator

Snapshots, Photos and Figures

IFC Based

Salubrity Criteria Checking
Minimum sunlight via IFC

Criteria of Calculation

Type of building	Day Room	Night Room
(Vertical Glass Area) / (Room Area)	1/12	1/12
(Roof Glass Area) / (Room Area)	1/14	1/14
Night Room	1.21798602279541	Ok
Night Room	2.174237541617951	Ok
Day Room	0.04741601249679	Ok

Room	Level	Room Type	Room Area	Vertical Glass Area	Roof Glass Area	Day Room Ratio	Night Room Ratio	Status
0.1 Chambre 2	Level 1	Night Room	1.027149	0	0	0	0	Ok
0.1 Hall of entrance	Level 0	Not a Living Room	0	0	0	0	0	Ok
0.2 WC	Level 0	Not a Living Room	0.239616	0	0	0	0	Ok
0.3 Buanderie	Level 0	Not a Living Room	0.239616	0	0	0	0	Ok
1.1 HCN	Level 1	Not a Living Room	0.399008	0	0	0	0	Ok
1.6 WC	Level 1	Not a Living Room	0.201152999999999	0	0	0	0	Ok
1.8 Salle de bain	Level 1	Not a Living Room	0.801152999999999	0	0	0	0	Ok
8.5.5 Corridors	Level 2	Not a Living Room	0	0	0	0	0	Ok

Native tools

Facade Sound Insulation
Calculate sound insulation inside facade

Room Area List

Room	Area
Room 1	1.027149
Room 2	2.174238
Room 3	0.047416
Room 4	0.399008
Room 5	0.201153
Room 6	0.801153
Room 7	0.801153
Room 8	0.801153
Room 9	0.801153
Room 10	0.801153
Room 11	0.801153
Room 12	0.801153
Room 13	0.801153
Room 14	0.801153
Room 15	0.801153
Room 16	0.801153
Room 17	0.801153
Room 18	0.801153
Room 19	0.801153
Room 20	0.801153
Room 21	0.801153
Room 22	0.801153
Room 23	0.801153
Room 24	0.801153
Room 25	0.801153
Room 26	0.801153
Room 27	0.801153
Room 28	0.801153
Room 29	0.801153
Room 30	0.801153
Room 31	0.801153
Room 32	0.801153
Room 33	0.801153
Room 34	0.801153
Room 35	0.801153
Room 36	0.801153
Room 37	0.801153
Room 38	0.801153
Room 39	0.801153
Room 40	0.801153
Room 41	0.801153
Room 42	0.801153
Room 43	0.801153
Room 44	0.801153
Room 45	0.801153
Room 46	0.801153
Room 47	0.801153
Room 48	0.801153
Room 49	0.801153
Room 50	0.801153

4.9. Demonstrator & Vision (Demo 9) / BIMy – BIM and GIS integration in architecture

Architects currently use a wide variety of incompatible tools to gather information about new project locations. This essential part of the design process often involves a lot of ‘digital labour’. A better integration of GIS and BIM could not only make this process more efficient, but also provide new, easy-to-use tools that support and improve the architect’s design process.

More broadly, it could be either interesting for everyone who has an interest in BIM and is professionally involved in building design, directly (architects, engineers, etc.) or indirectly (city planners, contractors, building owners, etc.)

The BIMy project integrates the worlds of BIM and GIS. Both developed independent of each other and have different (active) user bases. This visionary demonstrator aims to pique interest in GIS among building design professionals, by demonstrating how they might be using GIS already (without realizing) and how better integration of the two domains can support their work.

Name of the tool/Application/similar	BIMy - BIM and GIS integration in architecture
Link	<i>To be published</i>
Partners Contributing	<i>Assar Architects, Willemen Construct</i>
Responsible researcher(s) for technical discussions	Geert Bekaert, Assar, gbk@assar.com Thomas Goossens, Assar, tgo@assar.com Lise Bibert, Willemen, lise.bibert@willemen.be Dieter Froyen, Willemen, dieter.froyen@willemen.be Steven Smolders, GIM NV, steven.smolders@gim.be
Description	<i>Urban context is an important source of information for architectural design. However, architects lack easy-to-use tools to collect the available data in integrate in their design process. While digitisation in the last few decades has made a lot more information publicly available, it often requires hours of ‘digital labor’ to collect, download, rework, reformat or even recreate so it can be used by architects.</i> <i>BIMy offers a solution: a one-stop platform where architects can access all relevant information in a practical 3D (BIM) format.</i>
Target Audience	<i>Architects and building designers</i>
Dissemination status	Public demonstration
Opinions & Feedback	<ul style="list-style-type: none"> ▪ <i>Advantages</i> <ul style="list-style-type: none"> ▪ <i>Better workflow efficiency</i> ▪ <i>Improve design quality</i> ▪ <i>Consistent source of data</i> ▪ <i>Visualize projects in their environment (without having to recreate it)</i> ▪ <i>Lower risk of unforeseen problems during construction</i> ▪ <i>Extended vision</i> <ul style="list-style-type: none"> ▪ <i>Upload created design</i>

- Access third party apps for analyses and services: line-of-sight analysis, shadow analysis, traffic impact, building permit, etc.

Snapshots, Photos and Figures

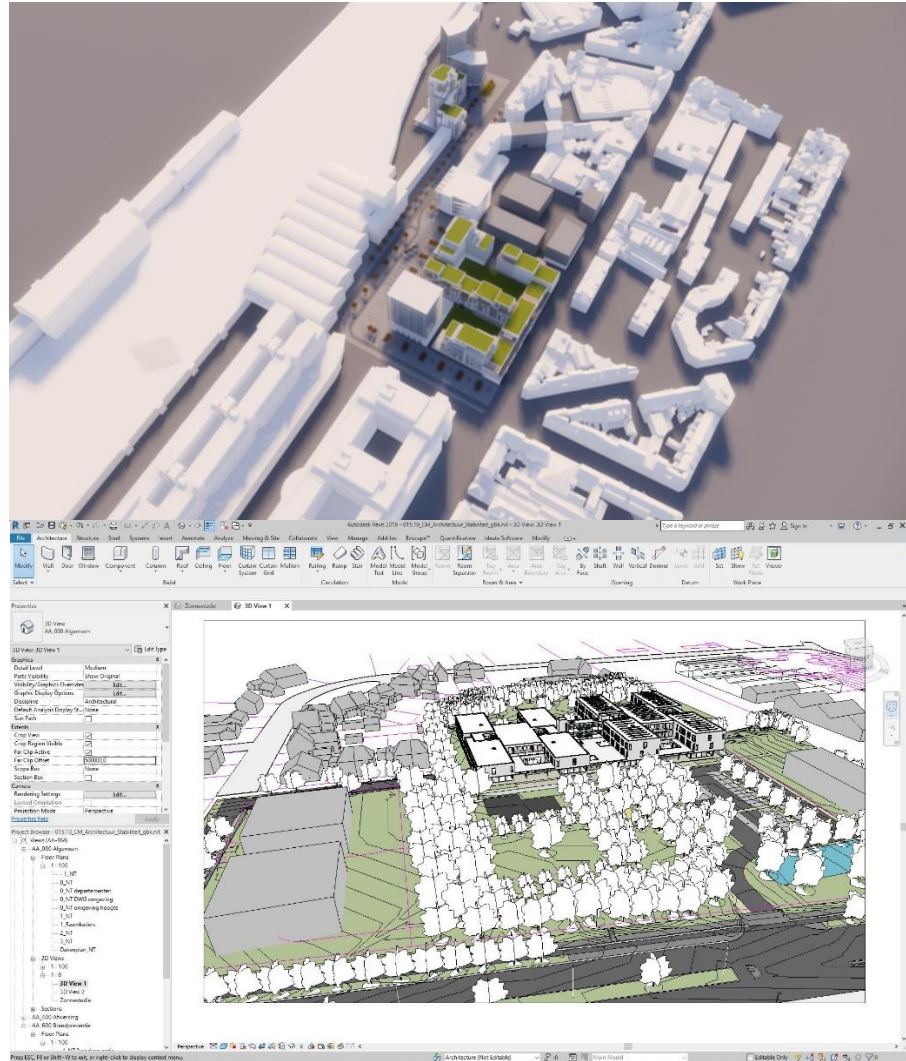
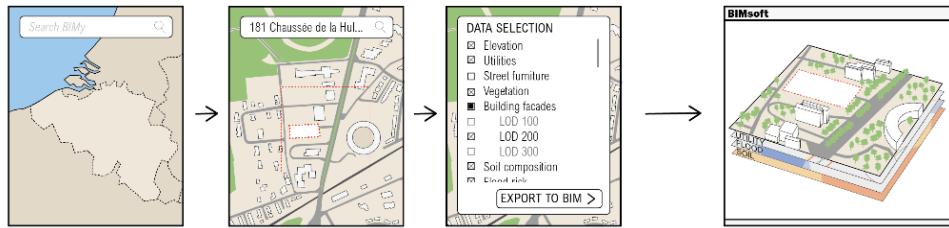

4.10. Demonstrator (Demo 10) / Security demo

Name of the tool/Application/ similar	BIMy HSM based security																								
Link	https://youtu.be/kF4AEfgVLhE																								
Partners Contributing	ERARGE, NETAS																								
Responsible researcher(s) for technical discussions	Alper KANAK Ph.D., ERARGE, alper.kanak@erarge.com.tr Ibrahim ARIF, ERARGE, ibrahim.arif@erarge.com.tr Osman Kumaş, NETAS, okumas@netas.com.tr Nagehan Çakır, NETAS, nagehanc@netas.com.tr																								
Description	<p>The Hardware Security Module (HSM) integration to BIMy Platform enables secure authentication and authorisation management via One-Time-Passwords (OTPs) for multifactor authentication, and role and profile based authorisation policy. Multiple profiles (Fireman, Building Owner, Architect, Administrator, etc.) are defined within BIMy end-users whilst every user has a role-based (Project Manager, Project Owner, Project Editor, Project User) access to the platform.</p> <p>On the other hand, data encryption and decryption for critical BIM models is applied by using AES-128bit algorithm. The BIMy Data Manager controls the encryption and decryption processes before updating and after downloading the model from Minio storage server. Thus, a server-side encryption is enabled on BIMy platform.</p> <p>OTP Mechanism:</p> <table border="1" data-bbox="457 997 1484 1407"> <tr> <td data-bbox="457 997 516 1081"></td> <td colspan="2" data-bbox="516 997 922 1081">Front-End Application</td> <td data-bbox="922 997 1484 1081">The user should enter the valid OTP that is shown as a captcha during registration/login screen</td> </tr> <tr> <td data-bbox="457 1087 516 1171"></td> <td data-bbox="516 1087 685 1171">Registration</td> <td data-bbox="685 1087 922 1171">Login</td> <td data-bbox="922 1087 1484 1171">During registration a role is assigned to the user. On both registration and further logins, an OTP is created for user validation</td> </tr> <tr> <td data-bbox="457 1178 516 1318" rowspan="2">HSM Based Cyber-Security</td> <td data-bbox="516 1178 597 1318">Authentication</td> <td data-bbox="597 1178 685 1318">Authorisation</td> <td data-bbox="685 1178 922 1318">Authentication</td> </tr> <tr> <td data-bbox="516 1325 597 1407">Authentication</td> <td data-bbox="597 1325 685 1407">Authorisation</td> <td data-bbox="685 1325 922 1407">Authorisation</td> </tr> <tr> <td data-bbox="922 1178 1484 1318"></td> <td colspan="2" data-bbox="922 1178 1484 1318"></td> <td data-bbox="922 1178 1484 1318">The hardware based authentication and authorisation server provides OTP validation to the users for secure, role-based access to the BIMy platform</td> </tr> <tr> <td data-bbox="457 1325 516 1407"></td> <td colspan="2" data-bbox="516 1325 922 1407">BIMy Platform</td> <td data-bbox="922 1325 1484 1407">BIMy Platform applications are available only for authenticated users and authorised user roles</td> </tr> </table> <p><i>Overall Architecture</i></p>			Front-End Application		The user should enter the valid OTP that is shown as a captcha during registration/login screen		Registration	Login	During registration a role is assigned to the user. On both registration and further logins, an OTP is created for user validation	HSM Based Cyber-Security	Authentication	Authorisation	Authentication	Authentication	Authorisation	Authorisation				The hardware based authentication and authorisation server provides OTP validation to the users for secure, role-based access to the BIMy platform		BIMy Platform		BIMy Platform applications are available only for authenticated users and authorised user roles
	Front-End Application		The user should enter the valid OTP that is shown as a captcha during registration/login screen																						
	Registration	Login	During registration a role is assigned to the user. On both registration and further logins, an OTP is created for user validation																						
HSM Based Cyber-Security	Authentication	Authorisation	Authentication																						
	Authentication	Authorisation	Authorisation																						
			The hardware based authentication and authorisation server provides OTP validation to the users for secure, role-based access to the BIMy platform																						
	BIMy Platform		BIMy Platform applications are available only for authenticated users and authorised user roles																						

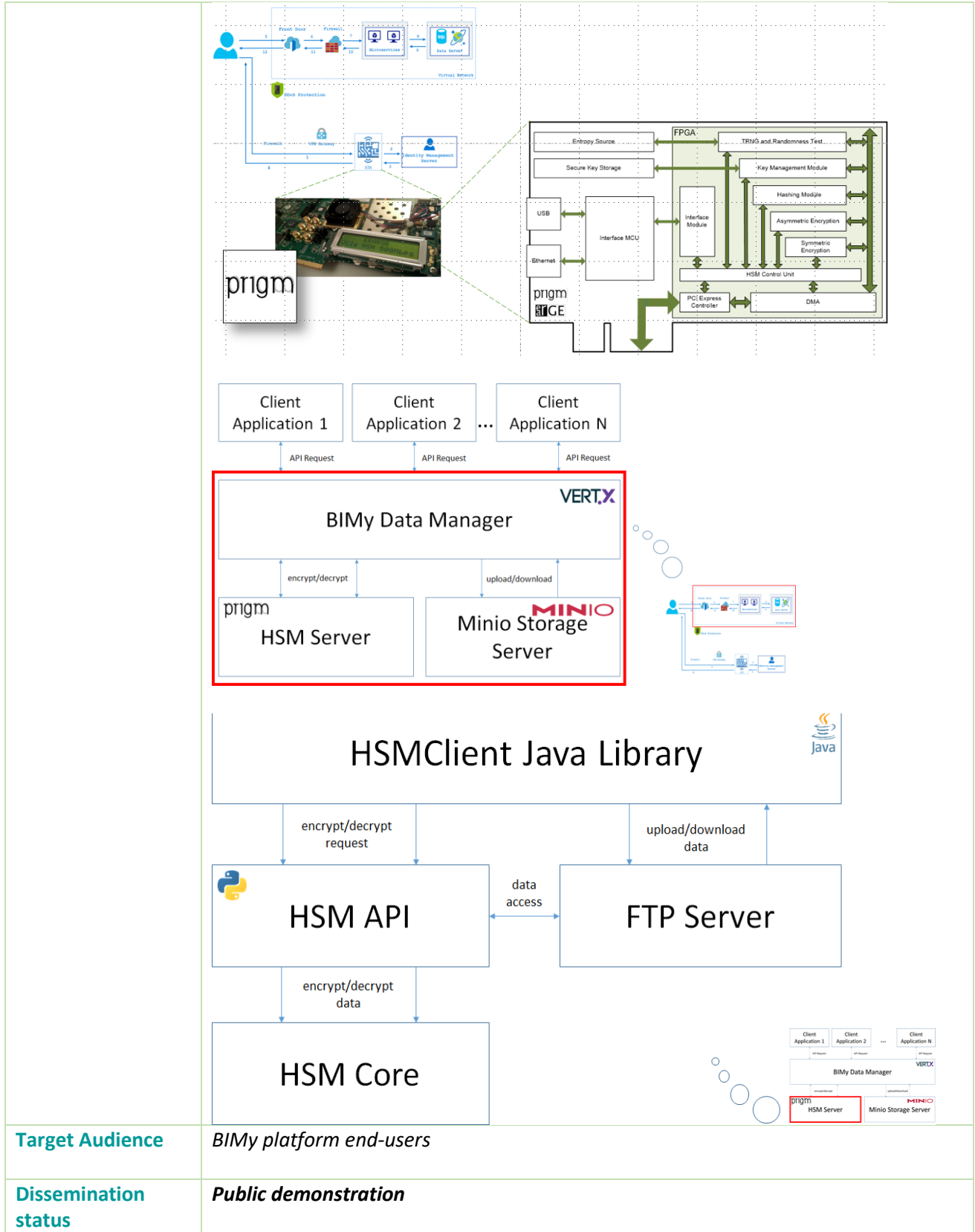

Target Audience

BIMy platform end-users

Dissemination status

Public demonstration

Opinions & Feedback

The HSM integration in BIMy platform reflects positively to its end-users for security policies. The optimisation of encryption and decryption time continues.

Snapshots, Photos and Figures

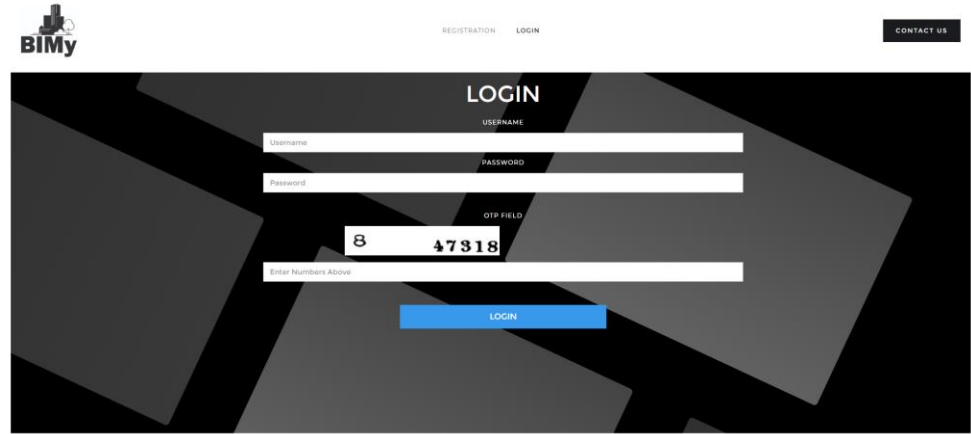

Original data

Encrypted data

Decrypted data

Three side-by-side screenshots showing data in its original state, its encrypted state, and its decrypted state, demonstrating the security process.

A screenshot of a web browser showing a file upload interface. A dialog box is open, displaying the upload progress of a file named 'File:Enc_Smiley-west_IFC2x3_FHMA_Allplan.ifc'.

Then, upload this to BIM server.

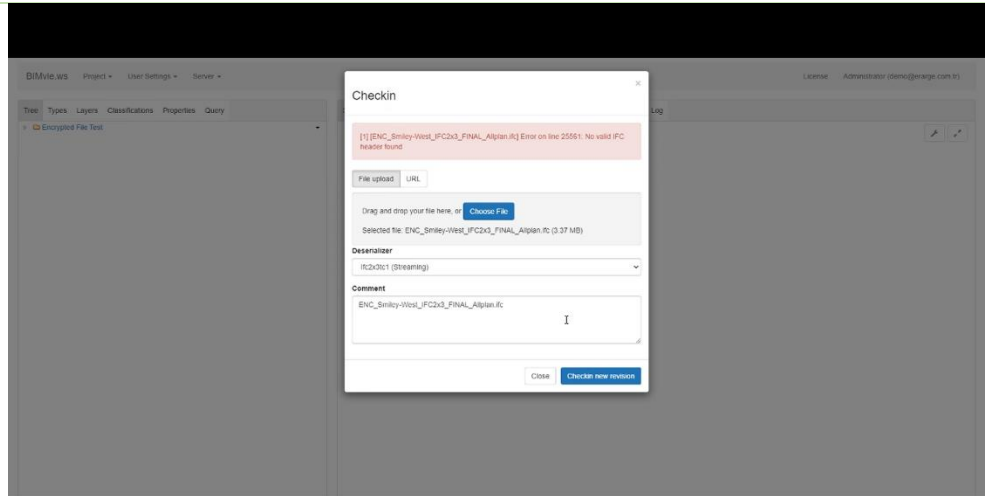

The upload operation is failed because the BIM model is encrypted

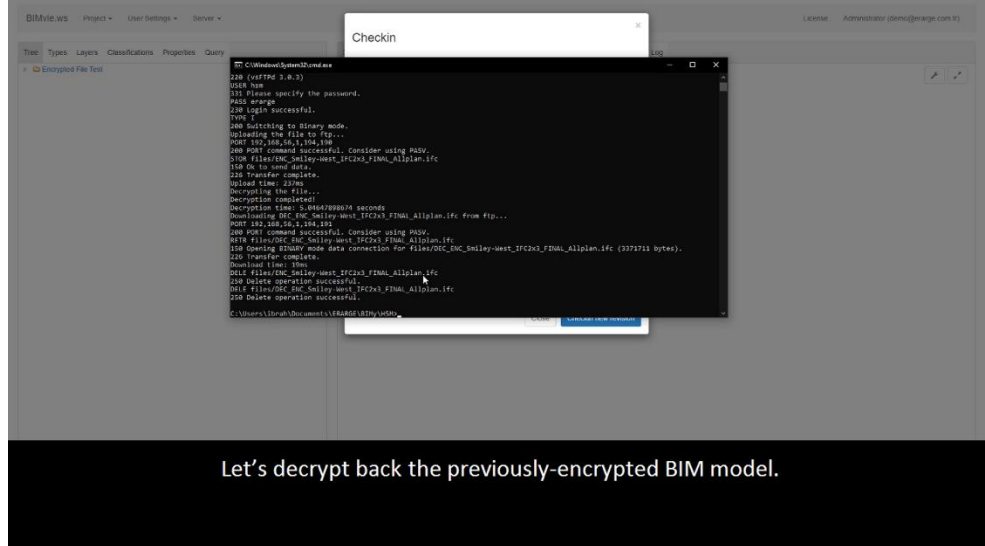

Let's decrypt back the previously-encrypted BIM model.

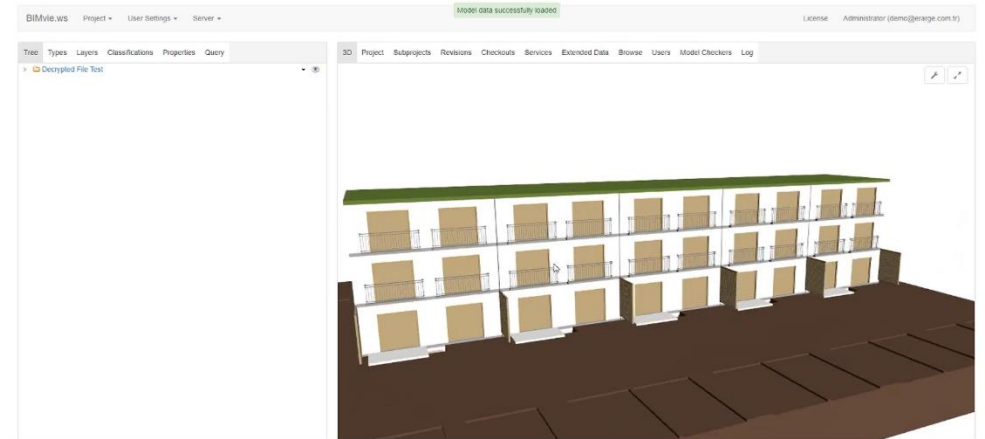

The decrypted BIM model is uploaded successfully because it is 100% same as its original version.

5. Qualified Assessment of BIMy

A questionnaire is applied to assess the subjects' experiences and identify needs, challenges and roles in a typical BIM and GIS project. The questionnaire is aimed to gather expert opinions about the use of BIM, GIS, IoT and the BIMy vision. The experts are selected mainly from four areas: i) AEC experts; ii) First responders and crisis management experts; iii) IT specialists working for the benefit of AEC and public safety, iv) Representatives of public organisations, e.g. municipalities and governmental authorities operating in related areas. The questionnaires were applied by bilateral discussions over a virtual chatroom and a set of questions were asked in five clusters as given in the following subsections:

5.1. Cluster I: Experts' Profile (A.General)

17 experts were participated in the questionnaire with the following profile who were selected from the experts working in large-scale operations. The experts are all from Turkey but have experience in international projects. The selection criteria seriously encounters the experts' active involvement in related areas of application and especially in multi-stakeholder projects. Table 2 presents the experts' profile.

Table 2. Experts' profile

		AEC Experts	First Responders	IT Specialists	Government/ Municipality
A.1	Number of participants	7 (1 female)	2 (1 female)	5 (2 females)	3 (all male)
A.2	Average Age	42,3	34,5	31,2	44,3
A.3	Education level	5 BS (civil engineering), 2 BS (Urban Planning)	2 BS (public safety related departments)	4 BS (Computer science) 1 MS (Electronics)	3 (public relations and social science)
A.4	Experience in relevant sectors (avg. Year)	18,6	12,5	8,2	19,3

5.2. Cluster II: BIM Awareness (B. Personal Experience)

The main objective of this cluster is to measure the BIM awareness by asking the following questions to measure the experts' personal experience in BIM. Since BIM is rather a new topic, it is normal that experts may not be very experienced in the proper use of BIM in their actual work. Table 3, presents the responses of experts to the questions. Experts asked to rank their response between 1 (lowest) and 5 (highest) and the results are given in terms of Mean Opinion Scores (MOS).

Table 3. Experts' feedback on BIM Awareness.

		Mean Opinion Scores (1: Lowest, 5: Highest)			
B. BIM Personal Experience		AEC Experts	First Responders	IT Specialists	Government / Municipality
B.1	How do you rate your Skills in BIM?	4,2	1	2,1	2,6

B.2	For how many years have you been working with BIM?	3,2	0,2	0,9	1
B.3	Do you hear more about BIM these days	4,8	3,5	4,2	2
B.4	BIM is indispensable in AEC sector, we need BIM to design sustainable buildings	4,8	NA	4	2
B.5	We need manufacturers to provide us assets/services with BIM objects	4,6	2,5	2,1	2
B.6	The industry is not clear enough on what BIM is yet	5	4,5	4,5	4
B.7	BIM is all about real time collaboration	2	2,5	2,1	3
B.8	BIM is all about software	2	2,5	2,5	3
B.9	BIM is only for new build, not renovation	1	2,5	1,6	2
B.10	BIM does not facilitate modified design or construction methods	1	1,5	1,6	2
B.11	BIM leads to weak buildings	1	1	1	1
B.12	BIM is just a synonym for 3D CAD drawings or these two are more or less the same	1	2,5	1	2

5.3. Cluster III BIM Awareness at Organisational Level (C. BIM Organisation Experience)

The main objective of the questions in Cluster III is to measure the level of BIM awareness at organisational level. Two critical questions were asked to understand at which level the experts' organisations are utilising BIM and which mainstream software they use. The responses to these questions are presented in Table 4 below:

Table 4. BIM awareness at organisational level.

C	BIM Organisation Experience	AEC Experts	First Responders	IT Specialists	Govern./Municipal
C.1	What is the highest level your organisation has reached in application of BIM on a project?	2D-3D modelling	NA	2D-3D modelling	2D-3D modelling
C.2	Which of the following tools do you mainly use?	Autodesk Revit (5) Autodesk AutoCAD (7)	Autodesk AutoCAD (2, for non BIM cases)	Autodesk Revit (2) Autodesk AutoCAD (3) Graphisoft ArchiCAD(1) Google Sketchup (2)	Autodesk AutoCAD (3)

5.4. Cluster IV. Demand Analysis (D. Demand on BIM-GIS-IoT combined solutions)

The questions in this clusters aim to measure the demand of main stakeholders on combined solutions integrating BIM, GIS and IoT. Question D.1 aims to understand in which geographical context the stakeholders consider building plans. Table 5 illustrates the experts' responses on questions.

Table 5. Demand analysis on solutions combining BIM, GIS and IoT

D	Demand on BIM-GIS-IoT combined solutions	AEC Experts	First Responders	IT Specialists	Government/Municipality
D.1	In which geographical context do you consider building plans ? [options: (a) 0-100m perimeter (parcel); (b) 100-500m perimeter (island); (c) 500m-a few kms(street); (d) larger area]	(a)→ 7; (b)→ 5; (c)→ 2; (d)→ 2;	(a)→ 2; (b)→ 2; (c)→ 1; (d)→ 2;	(a)→ 5; (b)→2; (c)→ 1; (d)→ 0;	(a)→ 1; (b)→3; (c)→ 3; (d)→ 3;
Mean Opinion Scores (1: Lowest, 5: Highest)					
D.2	Do you rely on quantitative data collected regularly from the field in your current operations?	4,2	4,5	4	4
D.3	Do you believe that BIM, GIS and any sensory data useful for disaster preparedness, and crisis planning, or management?	4,8	5	4	4
D.4	Do you believe that BIM, GIS and any sensory data useful for estimating the amount of recyclable asset or output?	4,2	2,5	4,2	4,3
D.5	Do you believe that BIM, GIS and any sensory data useful for taking the building permit or any certification of AEC project?	4,8	3,5	4,5	4,3
D.6	Do you believe that BIM, GIS and any sensory data useful for salubrity or building/construction health checking?	4,8	3	4,2	3,6
D.7	Do you believe that BIM, GIS and any sensory data useful for urban planning, renovation and transformation?	4,8	3	4,2	4,3
D.8	Do you believe that BIM, GIS and any sensory data useful for energy efficiency management in urban context?	4,2	2,5	4,2	3
D.9	Do you believe that BIM, GIS and any sensory data useful for energy efficiency management in building context?	4,6	2,5	4,2	3
D.10	Do you believe that BIM, GIS, and any sensory data useful for waste management and greener environments?	3,8	2	4	3
D.11	Do you believe 3D virtual reality and interactive visualisation technologies help	4	3	3	3

	you present or promote your AEC projects to customers ?				
D.12	Do you believe 3D virtual reality and interactive visualisation technologies help you manage your AEC projects better in multisatkeholder collaborative settings?	3,6	NA	3,2	2,8
D.13	Do you believe Augmented Reality or similar technologies help you improve the construction processes or management of AEC projects?	3,2	NA	2,8	2,8
D.14	Do you believe visualisation and interaction technologies should utilise BIM, GIS and IoT sensory data?	4,8	4,5	4	4
D.15	Do you need online services to manage BIM, GIS and IoT data in your company?	4,8	4,5	4	4,3
D.16	Do you need online services to manage BIM, GIS and IoT data in multistakeholder or cooperative/joint operations?	4,8	4	4,5	4,3
D.17	Do you need multi-purpose set of applications that can afford the diversity in data formats?	3,8	3	4,5	4,3

5.5. Cluster V. BIMy Assessment (E. Opinions on BIMy)

In this cluster experts are invited to share their opinions about BIMy. The questions aim to understand what stakeholder think about BIMy vision and how BIMY solutions can be used in their actual operations. Table 6 presents their responses to the questions listed below.

Table 6. BIMy Assessment

E Opinions on BIMy		AEC Experts	First Responders	IT Specialists	Govern./Municip.
Mean Opinion Scores (1: Lowest, 5: Highest)					
E.1	Do you believe BIMy may address your needs on online services to manage BIM, GIS and IoT data in your company?	4,2	3,5	3	3,2
E.2	Do you believe BIMy may address your needs on online services to manage BIM, GIS and IoT data in multistakeholder or cooperative/joint operations?	4,2	3,8	2,5	3,2
E.3	Do you believe BIMy may address your needs on affording the diversity in data formats?	3,8	3	2	3,2
E.4	Do you believe BIMy has the potential to migrate your operations on it over cloud?	3,4	2	2	2
E.5	Do you believe BIMy may meet the collaboration and cooperation requirements of AEC stakeholders?	3,4	NA	2,5	2

E.6	Do you believe BIMy may meet the collaboration and cooperation requirements of disaster and crisis management stakeholders, first responders or relief organisations?	3	3	2,5	2
E.7	Do you believe BIM may meet the needs of public authorities, e.g. Regulatory check, building permit, certification?	3	NA	3,8	3,2

5.6. Discussion

The selected experts have significant experience in their fields as all of them have taken active roles in building- and urban-level projects. Among these, as expected, AEC experts are more familiar with BIM activities as they believe BIM is becoming indispensable in their operations. IT specialists are also familiar with the BIM concept and they are aware of increasing demand on ICT to improve building life cycle. All partners believe that industry is still not clear enough on what BIM is all about. There is a significant finding that first responders are getting more aware about BIM but this is not at this level when the representatives of governments or municipalities are considered.

At organisational level, BIM users do not apply higher level of BIM as they stay at 3D at most. Autodesk tools, especially Revit and AutoCAD, are widely preferred. AutoCAD is widely used by all profiles but IT specialists are more open to other tools liked Graphisoft ArchiCAD and Google Sketchup.

Despite the fact that BIM is still not widely adopted, all experts think that integrated solutions that cover building and urban information are seriously needed. Effective management of building data, GIS data and any IoT data can increase the efficiency of their operations. Visualisation technologies have the capacity to increase the awareness of people and even can help them to improve their operations. Nearly all partners can see the potential of such integrated solutions and their uses in a wide context including energy optimised buildings and districts, waste management, crisis management, municipal operations, etc. However, participated experts are still sceptic about the use AR in related contextual application areas, even the VR. Nevertheless, these technologies can be useful for the promotion and awareness activities.

Expert opinions on BIMy are positive in general. They believe BIMy may address their needs on online services to manage BIM, GIS and IoT data in their operations. BIMy is seen useful especially for multistakeholder or cooperative/joint operations. However, BIMy needs more attention, improvement and promotional activities to convince these users. Nevertheless, the AEC sector seems more ready for the BIMy adoption which can be used as a driving force to exploit project results after the project is finished.

6. Conclusion

This deliverable presents an overview of the demonstrated project outputs which are presented during the iteration #2. These demonstrators mainly focus on the consolidation of fundamental features of the BIMy cloud platform like BIM data management, advanced applications for fire and disaster preparedness applications built by the circular economy and Green Deal mind-set, building permit and model checking. The demonstrators apply sophisticated technologies including artificial intelligence to detect anomalies for better cyber resilience to protect data of critical infrastructures, and augmented and virtual reality enabling more effective and charming interaction with users.

Due to Covid19 outbreak and in spite of the unforeseen latencies, BIMy consortium managed the process successfully and succeed to present influential demonstrators and visionary articles to increase the impact of the project. As contrary to the first year iterations (see D5.1 v1), the demonstrators presented in this report are significantly more collaborative as both Turkish and Belgian partners have worked in coherence.

These demonstrators are jointly improved because they all rely on the BIMy vision. Partners focus on evaluating the results and collect feedback from the stakeholders by applying questionnaires. Such a feedback help BIMy partners to re-elicite and improve their research, marketing and business plans. These revisions will be a baseline for future large-scale projects or products and better engagement in standardisation and public-private partnership projects.



Bibliography

BIMy consortium. (2020). *BIMy—BIM in the City—D4.2 v1 Report for business and exploitation models.*